

ROBE

ROBIN[®] 300X

LedWash

ROBIN[®] 300X

LedWash Wireless DMX

CRMX™

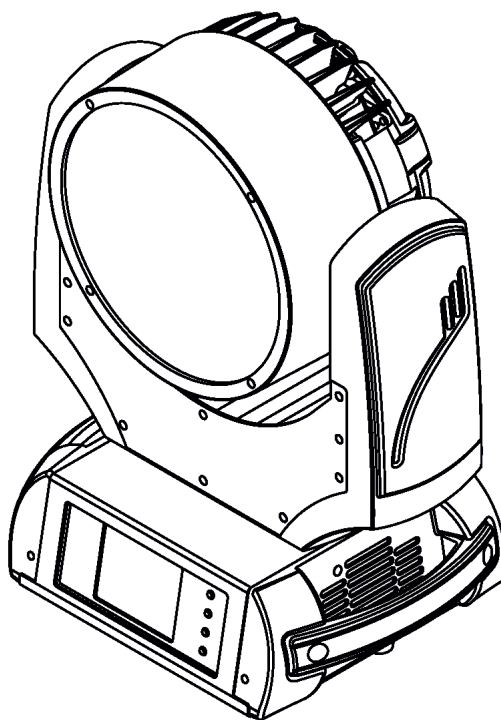

ROBE
Innovative
Technology

QR code for user manual



USER MANUAL

ROBE[®] lighting s.r.o. • Czech Republic • www.robe.cz

Version 1.1

Robin 300X LEDWash

Robin 300X LEDWash Wireless DMX

Table of contents

1. Safety instructions	3
2. Fixture exterior view	5
3. Installation	6
3.1 Connection to the mains	6
3.2 Installing the top hat	7
3.3 Installing the eggcrate	8
3.4 Rigging the fixture	9
3.5 DMX-512 connection.....	11
3.6 Ethernet connection	12
4. Control menu map	14
4.1 LED zone order	16
5. Control menu	17
5.1 Tab "Address"	18
5.2 Tab "Information"	19
5.3 Tab "Personality"	20
5.4 Tab "Manual Control".....	21
5.5 Tab "Stand-alone"	21
5.6 Tab "Service"	23
6. RDM	25
7. Wireless DMX operation	25
8. Error and information messages	26
9. Technical Specifications	27
10. Maintenance and cleaning	29
10.1 Replacing fuse	29
11. Photometric diagrams	30

**FOR YOUR OWN SAFETY, PLEASE READ THIS USER MANUAL CAREFULLY
BEFORE POWERING OR INSTALLING YOUR ROBIN 300X LEDWASH !**

Save it for future reference.

This device has left our premises in absolutely perfect condition. In order to maintain this condition and to ensure a safe operation, it is absolutely necessary for the user to follow the safety instructions and warning notes written in this manual.

The manufacturer will not accept liability for any resulting damages caused by the non-observance of this manual or any unauthorized modification to the device.

Please consider that damages caused by manual modifications to the device are not subject to warranty.

The Robin 300X LEDWash was designed for indoor use and it is intended for professional application only. It is not for household use.

1. Safety instructions

DANGEROUS VOLTAGE CONSTITUTING A RISK OF ELECTRIC SHOCK IS PRESENT WITHIN THIS UNIT!

Make sure that the available voltage is not higher than stated on the rear panel of the fixture. This fixture should be operated only from the type of power source indicated on the marking label. If you are not sure of the type of power supplied, consult your authorized distributor or local power company.

Always disconnect the fixture from AC power before cleaning, removing or installing the fuses, or any part.

Make sure that the power switch is set to off-position before you connect the fixture to the mains. The power plug has to be accessible after installing the fixture. Do not overload wall outlets and extension cords as this can result in fire or electric shock.

Do not allow anything to rest on the power cord. Do not locate this fixture where the cord may be damaged by persons walking on it.

Make sure that the power cord is never crimped or damaged by sharp edges. Check the fixture and the power cord from time to time.

Refer servicing to qualified service personnel.

This fixture falls under protection class I. Therefore this fixture has to be connected to a mains socket outlet with a protective earthing connection.

Do not connect this fixture to a dimmer pack.

**LED light emission. Risk of eye injury. Do not look straight at the fixture's LED source during operation. The intense light beam may damage your eyes.
Do not view the light output with optical instruments or any device that may concentrate the beam.**

If the fixture has been exposed to drastic temperature fluctuation (e.g. after transportation), do not switch it on immediately. The arising condensation water might damage your device. Leave the device switched off until it has reached room temperature.

Do not shake the fixture. Avoid brute force when installing or operating the fixture.

This fixture was designed for indoor use only, do not expose this unit to rain or use near water.

When choosing the installation spot, please make sure that the fixture is not exposed to extreme heat, moisture or dust.

Air vents and slots in the fixture's head and base are provided for ventilation, to ensure reliable operation of the device and to protect it from overheating.

Do not block the LEDs array with any object when the fixture is under operation.

The openings should never be covered with cloth or other materials, and never must be blocked.

This fixture should not be placed in a built-in installation unless proper ventilation is provided.

Only operate the fixture after having checked that the housing is firmly closed and all screws are tightly fastened.

Always use a secondary safety cable when mounting this fixture.

Make sure that the area below the installation place is blocked when rigging, derigging or servicing the fixture.

Do not block the front objective LEDs with any object when the fixture is under operation.

The fixture becomes very hot during operation. Allow the fixture to cool approximately 20 minutes prior to manipulate with it.

Operate the fixture only after having familiarized with its functions. Do not permit operation by persons not qualified for operating the fixture. Most damages are the result of unprofessional operation!

Please use the original packaging if the fixture is to be transported.

Please consider that unauthorized modifications on the fixture are forbidden due to safety reasons!

If this device will be operated in any way different to the one described in this manual, the product may suffer damages and the guarantee becomes void. Furthermore, any other operation may lead to dangers like short-circuit, burns, electric shock, crash etc.

Immunity of the equipment is designed for electromagnetic environments E1, E2, E3 according to the standard EN55103-2 ed.2 Electromagnetic compatibility. Product family standard for audio, video, audiovisual and entertainment lighting control apparatus for professional use. Part 2: Immunity.

The installation company should check levels of possible interferences above the tested levels E1,E2,E3 given by this standard (e.g. transmitters in surrounding area) before installing the equipment.

Emission of the equipment complies with the standard EN55032 Electromagnetic compatibility of multimedia equipment – Emission Requirements according to class B.

2. Fixture exterior view

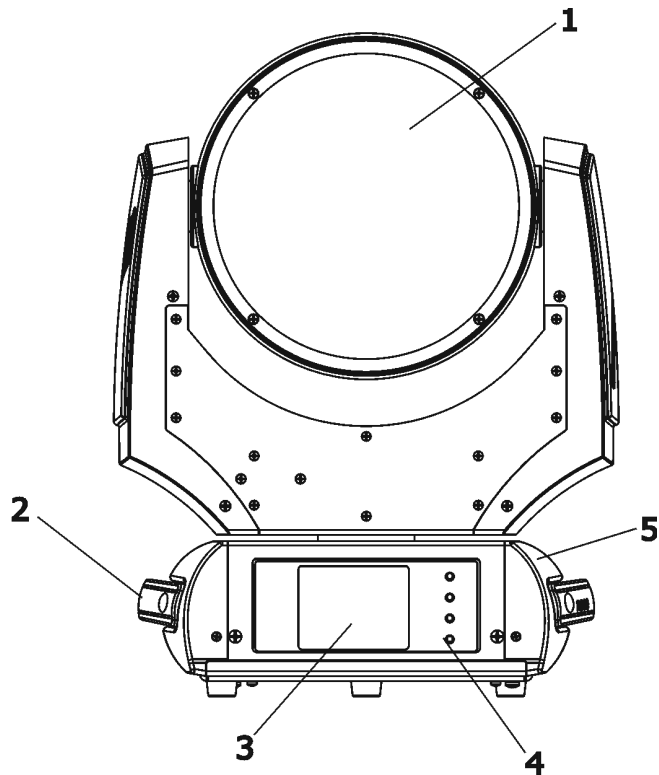

- 1 - Lens array
- 2 - Hold for safety cabel
- 3 - QVGA touch screen
- 4 - Control buttons
- 5 - Base

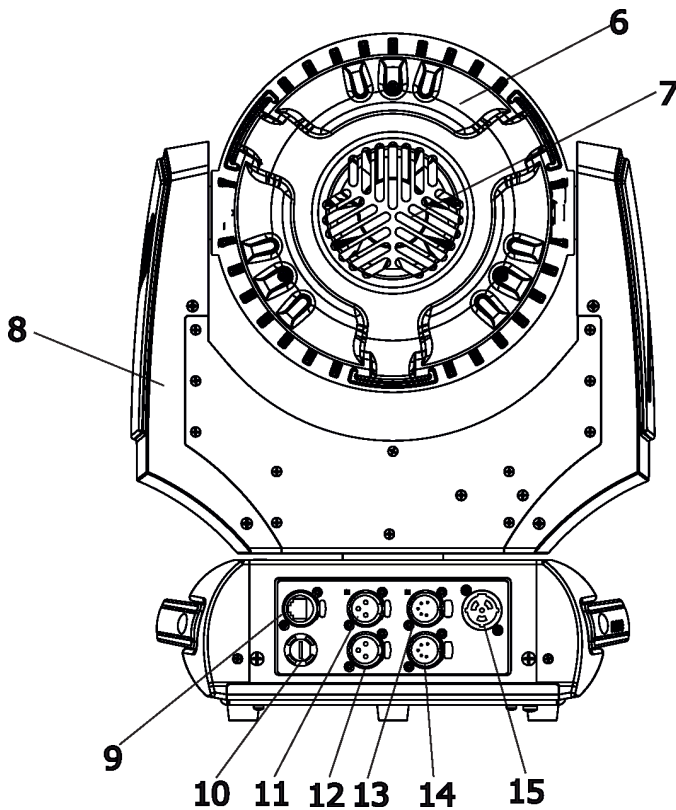

Rear panel of the base:

- 6 - Rear head cover
- 7 - Fan
- 8 - Yoke
- 9 - Ethernet
- 10 - Fuse
- 11 - 3-pin DMX IN
- 12 - 3-pin DMX OUT
- 13 - 5-pin DMX IN
- 14 - 5-pin DMX OUT
- 15 - Power (PowerCon True 1)

The ENTER/DISPLAY ON button also serves for switching the display on when the fixture is disconnected from the mains.

3. Installation



Fixtures must be installed by a Qualified electrician in accordance with all national and local electrical and construction codes and regulations.

3.1 Connection to the mains

For protection from electric shock, the fixture must be earthed!

The Robin 300X LEDWash is equipped with auto-switching power supply that automatically adjusts to any 50/60Hz AC power source from 100-240 Volts.

Power cable is enclosed to the fixture. If you need to install a power plug on the power cable to allow connection to power outlets, install a grounding-type (earthed) plug, following the plug manufacturer's instructions. If you have any doubts about proper installation, consult a qualified electrician.

Core (EU)	Core (US)	Connection	Plug Terminal Marking
Brown	Black	Live	L
Light blue	White	Neutral	N
Yellow/Green	Green	Earth	

3.2 Installing the top hat

Switch off the fixture before top hat installation

1. Go to the fixture menu and set reduced tilt movement (Personality --> Pan/Tilt Setting--> Tilt Movement Range --> reduced).
2. Unscrew the four fastening screws (3) which securing flange (4) to the head (5) and install new flange. Keep its right position- the cutouts (A) in the flange must look towards the arms.

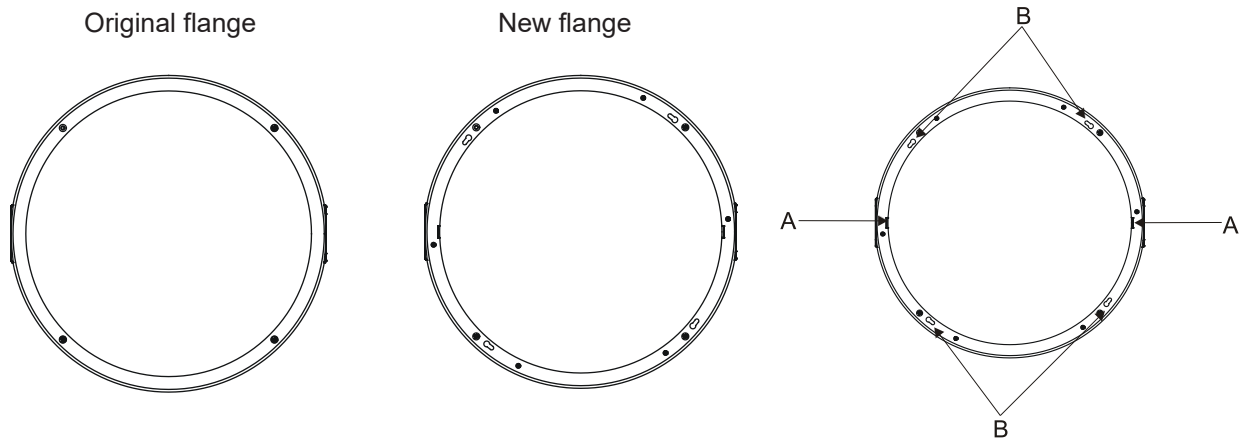

3. Place the top hat (1) on the head (5), press locks (2) and turn the top hat counter-clockwise until it snap into slots (B) in the flange.

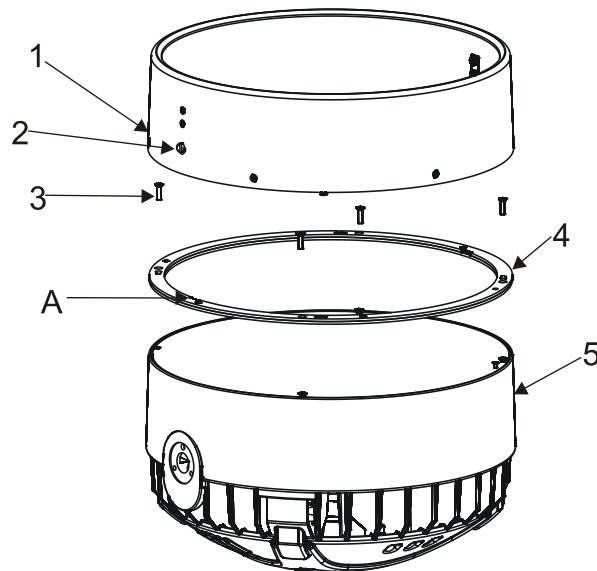

3.3 Installing the eggcrate

Switch off the fixture before top hat installation

1. Unscrew the four fastening screws (1) which securing top flange (2) to the head (7) and remove both flange and transparent plastic cover (3) from the head.
2. Unscrew the three fastening screws (4) which securing black eggcrate (5) to the zoom module (6) and remove it.
3. Put the transparent eggcrate on the zoom module (6) and screw it with three screws (4) with washers to the zoom module (6).
4. Place the transparent cover (3) and the top flange (2) back to the head and secure it with four screws (1).

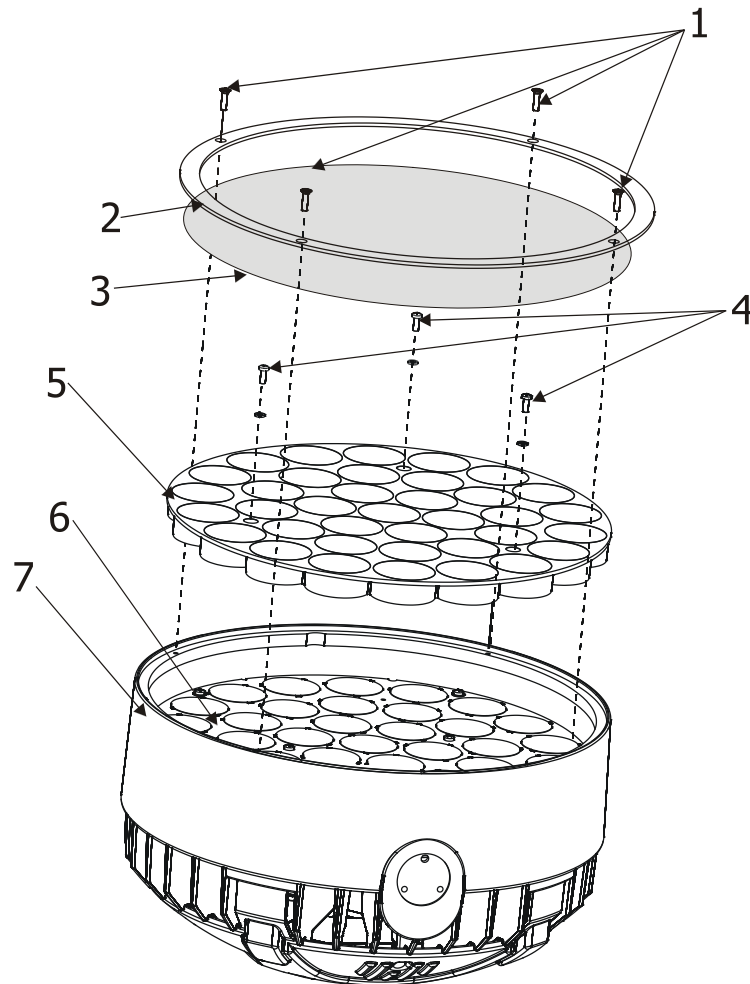

3.4 Rigging the fixture

The installation of the fixture has to be built and constructed in a way that it can hold 10 times the weight for 1 hour without any harming deformation.

The installation must always be secured with a secondary safety attachment, e.g. an appropriate catch net. This secondary safety attachment must be constructed in a way that no part of the installation can fall down if the main attachment fails.

When rigging, derigging or servicing the fixture staying in the area below the installation place, on bridges, under high working places and other endangered areas is forbidden.

The operator has to make sure that safety-relating and machine-technical installations are approved by an expert before taking into operation for the first time and after changes before taking into operation another time.

The operator has to make sure that safety-relating and machine-technical installations are approved by an expert after every four year in the course of an acceptance test.

The operator has to make sure that safety-relating and machine-technical installations are approved by a skilled person once a year.

The fixture should be installed outside areas where persons may walk by or be seated.

IMPORTANT! OVERHEAD RIGGING REQUIRES EXTENSIVE EXPERIENCE, including (but not limited to) calculating working load limits, installation material being used, and periodic safety inspection of all installation material and the projector. If you lack these qualifications, do not attempt the installation yourself, but instead use a professional structural rigger. Improper installation can result in bodily injury or damage to property. The fixture has to be installed out of the reach of people.

If the fixture shall be lowered from the ceiling or high joists, professional trussing systems have to be used. The fixture must never be fixed swinging freely in the room.

Caution: Fixture may cause severe injuries when crashing down! If you have doubts concerning the safety of a possible installation, do not install the moving head!

Before rigging make sure that the installation area can hold a minimum point load of 10 times the fixture's weight.

When installing the device, make sure there is no highly inflammable material (decoration articles, etc.) in a distance of min. 0.5 m.

CAUTION!
Use an appropriate clamp to rig the fixture on the truss.
Follow the instructions mentioned at the bottom of the base.
Make sure that the device is fixed properly! Ensure that the structure (truss) to which you are attaching the fixtures is secure.

The fixture can be placed directly on the stage floor or rigged in any orientation on a truss without altering its operation characteristics .

For securing a fixture to the truss install a safety wire that can hold at least 10 times the weight of the fixture. Use only the safety wire with a snap hook with screw lock gate. Pull the safety wire through the carrying handles and around the truss as shown on the pictures below.

Note: If the safety wire is too long, whip it several times around the trusses in order to attach the fixture tight. In case of an accident, the way of the falling fixture will be short.

Securing the fixture via one safety wire

Securing the fixture via two safety wires

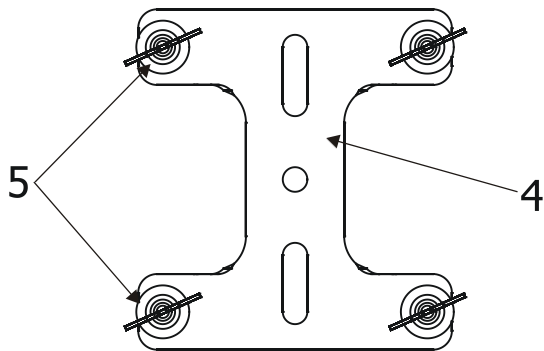
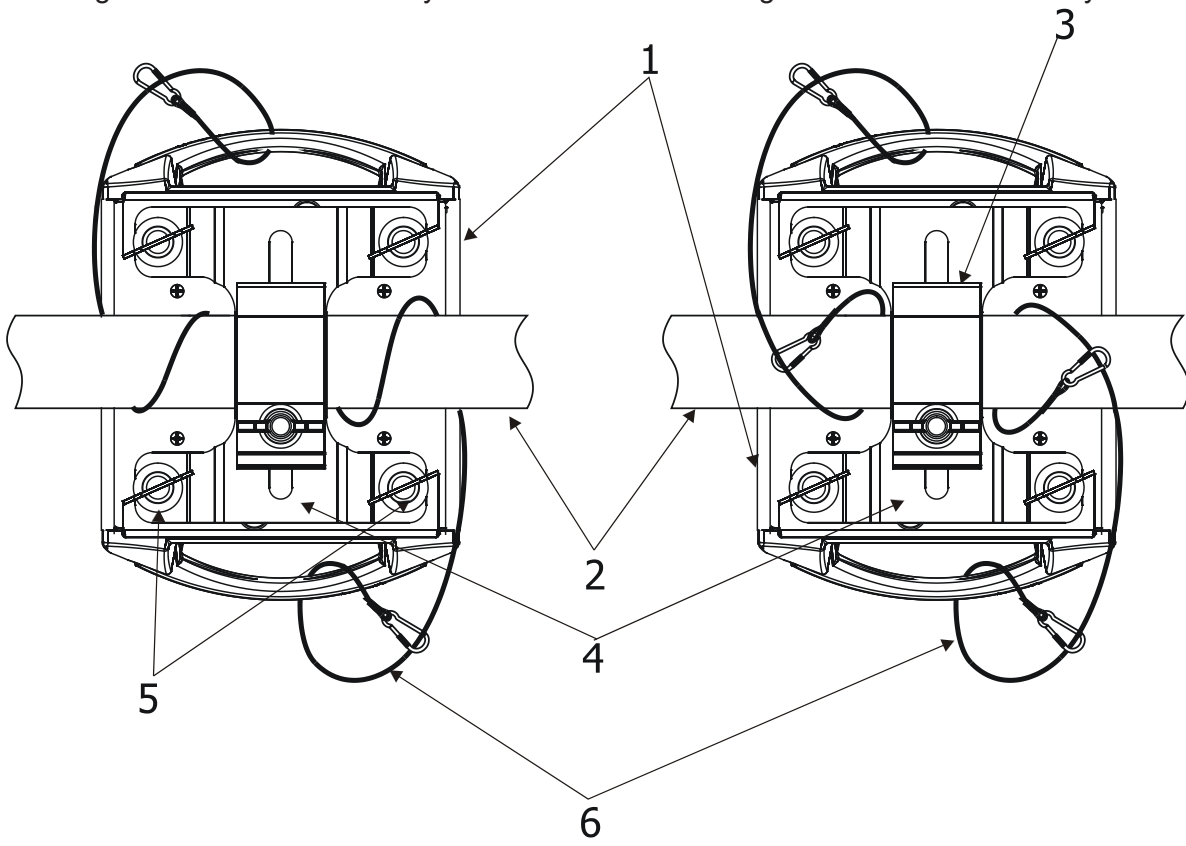

- 1-Fixture
- 2-Truss
- 3-Clamp
- 4-Mounting adaptor
- 5-Quarter-turn fasteners
- 6-Safety wire

3.5 DMX-512 connection

The fixture is equipped with both 3-pin and 5-pin XLR sockets for DMX input and output. The sockets are wired in parallel.

Only use a shielded twisted-pair cable designed for RS-485 and 3-pin or 5-pin XLR-plugs and connectors in order to connect the controller with the fixture or one fixture with another.

DMX - output

XLR mounting-sockets (rear view):

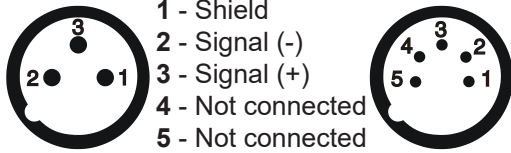

DMX-input

XLR mounting-plugs (rear view):

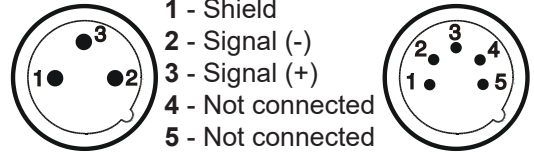

If you are using the standard DMX controllers, you can connect the DMX output of the controller directly with the DMX input of the first fixture in the DMX-chain. If you wish to connect DMX-controllers with other XLR-outputs, you need to use adapter-cables.

Building a serial DMX-chain:

Connect the DMX-output of the first fixture in the DMX-chain with the DMX-input of the next fixture. Always connect one output with the input of the next fixture until all fixtures are connected.

Caution: At the last fixture, the DMX-cable has to be terminated with a terminator. Solder a 120 Ω resistor between Signal (-) and Signal (+) into a 3-pin XLR-plug and plug it in the DMX-output of the last fixture.

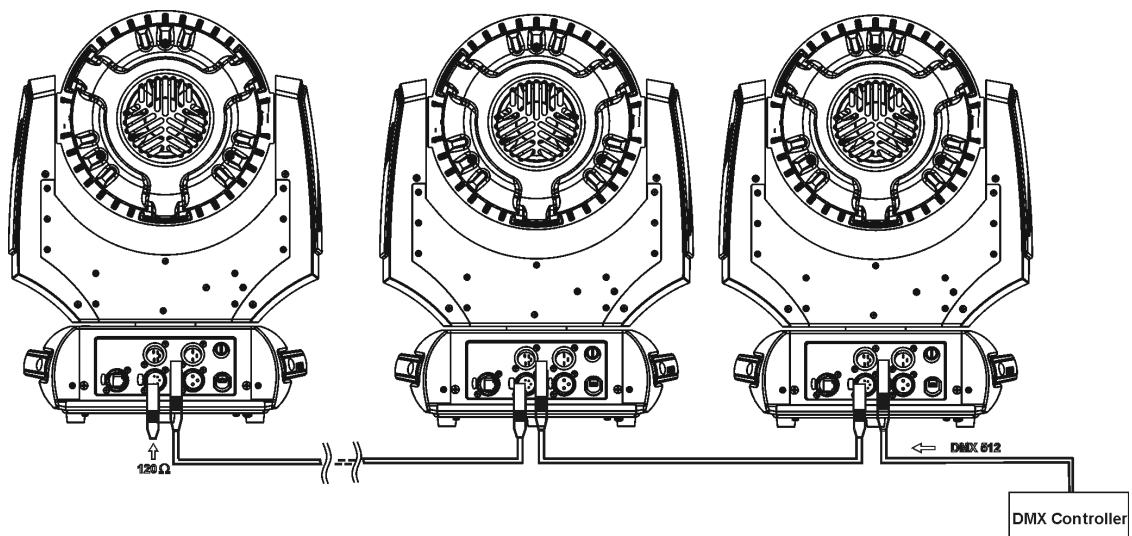

3.6 Ethernet connection

The fixtures on a data link are connected to the Ethernet with ArtNet communication protocol. The control software running on your PC (or light console) has to support Art-Net protocol.

Art-Net communication protocol is a 10 Base T Ethernet protocol based on the TCP/IP. Its purpose is to allow transfer of large amounts of DMX 512 data over a wide area using standard network technology.

IP address is the Internet protocol address. The IP uniquely identifies any node (fixture) on a network.

The Universe is a single DMX 512 frame of 512 channels.

The Robin 300X LedWash is equipped with 8-pin RJ-45 socket for Ethernet input. Use a network cable category 5 (with four "twisted" wire pairs) and standard RJ-45 plugs in order to connect the fixture to the network.

RJ-45 socket (front view):

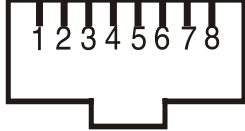

- 1- TD+
- 2- TD-
- 3- RX+
- 4- Not connected
- 5- Not connected
- 6- RX-
- 7- Not connected
- 8- Not connected

RJ-45 plug (front view):

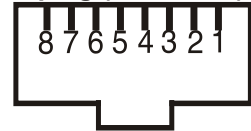

Patch cables that connect fixtures to the hubs or LAN sockets are wired 1:1, that is, pins with the same numbers are connected together:



If only the fixture and the computer are to be interconnected, no hubs or other active components are needed. A cross-cable has to be used:



If the fixture is connected with active Ethernet socket (e.g. switch) the network icon  will appear at the bottom right corner of the screen:

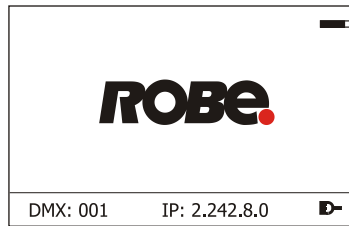

Direct Ethernet operation

Connect the Ethernet inputs of all fixtures with the Ethernet network.

Option "Artnet/MaNet" has to be selected from "Ethernet Mode" menu on the fixture.

Set IP address (002.xxx.xxx.xxx / 010.xxx.xxx.xxx) and the Universe.

(DMX address=46)
IP address=002.168.002.004
Universe=1

(DMX address=23)
IP address=002.168.002.003
Universe=1

(DMX address=1)
IP address=002.168.002.002
Universe=1

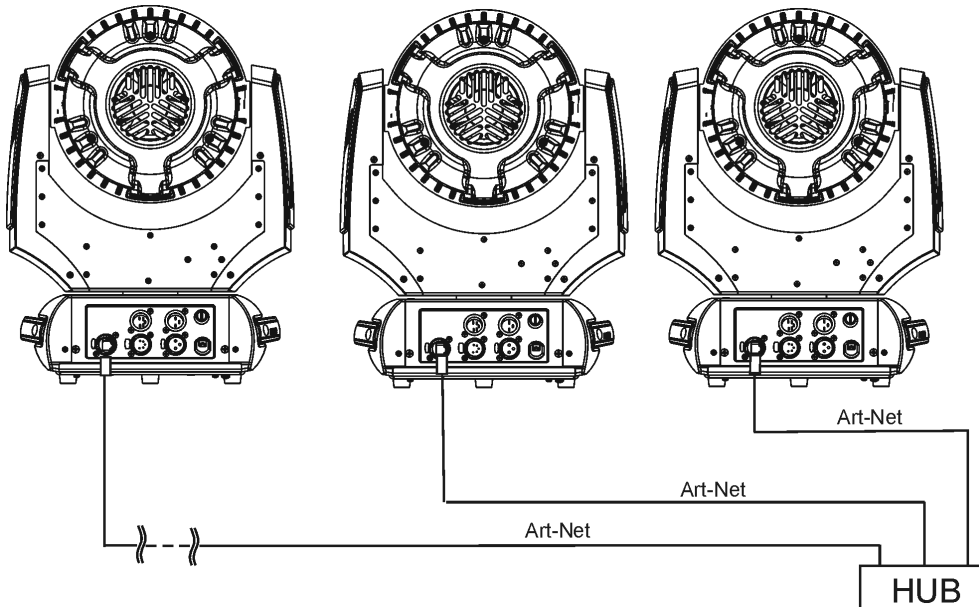

An advised PC setting: IP address: 002.xxx.xxx.xxx / 010.xxx.xxx.xxx (Different from fixture IP addresses)
NET mask: 255.0.0.0

Ethernet / DMX operation

Options "Ethernet/DMX" has to be selected from the "Ethernet Mode" menu on the first fixture (connected to the Ethernet) in the fixture chain, next fixtures have standard DMX setting.

Connect the Ethernet-input of the first fixture in the data chain with the network. Connect the DMX output of this fixture with the input of the next fixture until all fixtures are connected to the DMX chain.

Caution: At the last fixture, the DMX chain has to be terminated with a terminator. Solder a 120 Ω resistor between Signal (-) and Signal (+) into a XLR-plug and connect it in the DMX-output of the last fixture.

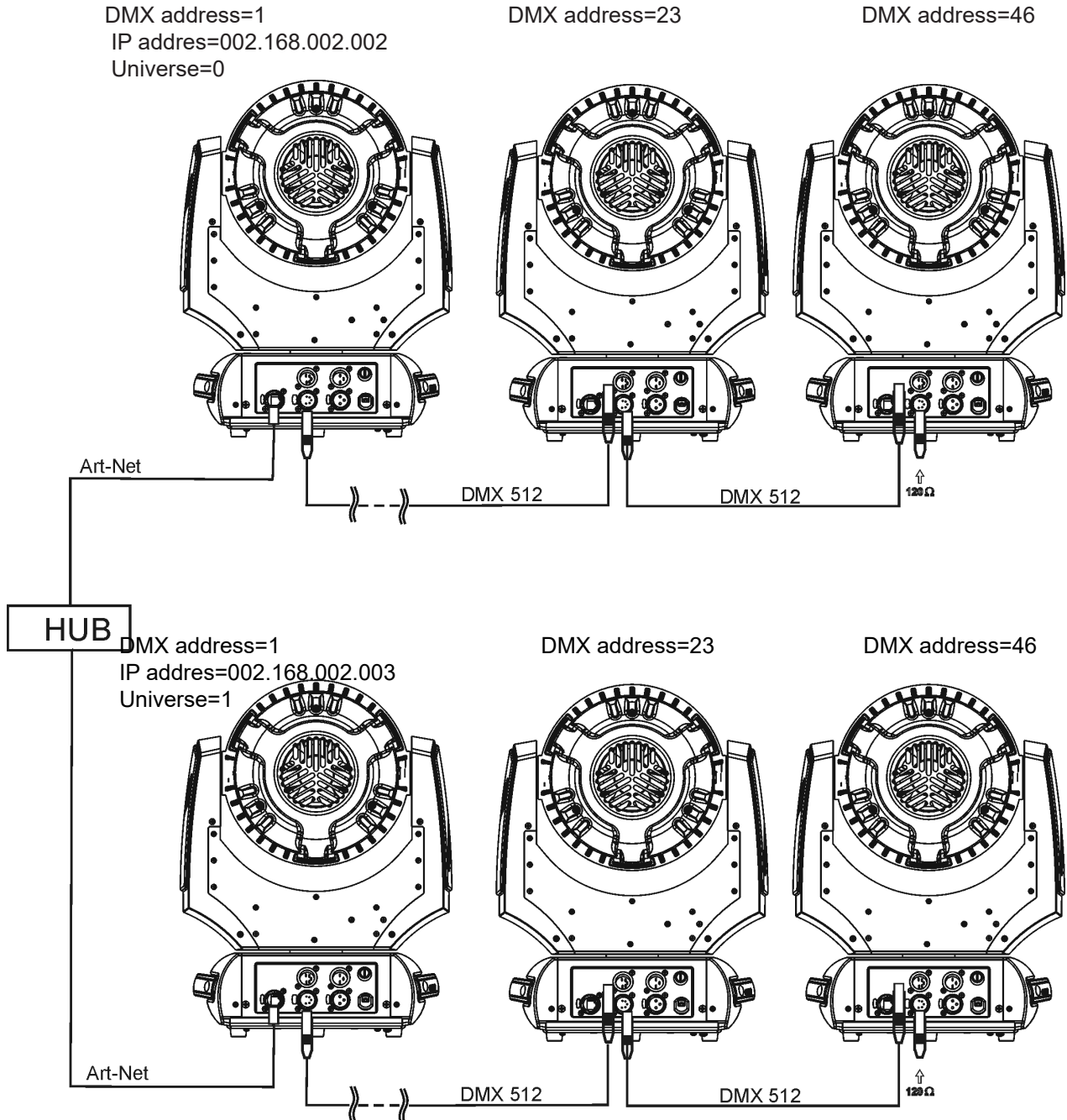

Example:



4. Control menu map

Default settings=**Bold print**

Tab	Level 1	Level 2	Level 3	Level 4	Level 5	Level 6	
Addressing	Settings	DMX Address	001-255				
		Ethernet Settings	Ethernet Mode	Disable			
				ArtNet			
				gMA1			
				gMA2			
				Art2DMX			
				IP Address/NetMask	Default IP Address		
					Custom IP Address		
					Net Mask		
				ArtNet Universe	0-255		
				MANet settings	MANet I/IIUniverse	1-256	
					MANet Session ID	1-32	
Information	Fixture Times	Power On Time	Total Hours				
			Resetable Hours				
	Fixture Temperatures	LEDs Temperature	Current				
			Maximum NonRes.				
			Maximum Res.				
		AmbientTemperature	Current				
			Maximum NonRes.				
			Maximum Res.				
		Base Temperature	Current				
			Maximum NonRes.				
			Maximum Res.				
	DMX Values	Pan					
		:					
		Dimmer Fine					
	Wireless State*	Linked To a Transmitter					
		Signal Quality:					
	Software Versions	Display System					
		Module M					
		Module L					
	Product IDs	Mac Address					
		RDM UID					
		RDM Label					
	View Logs	Fixture Errors					
		Fixture Status	Power On				
			Power Off				
		Fixture Position					
		Fixture Temperatures	LEDs Temperature				
			Ambient Temperature				
			Base Temperature				
Personality	User Mode	User A Settings					
		User B Settings					
		User C Settings					
	DMX Presets	Mode 1					
		Mode 2					
		Mode 3					
		Mode 4					
		Mode 5					
			View Selected Preset				
		Pan/Tilt Settings	Pan Reverse	Off , On			

Tab	Level 1	Level 2	Level 3	Level 4	Level 5	Level 6
		Tilt Reverse	Off, On			
		Pan/Tilt Feedback	Off, On			
		Pan/Tilt mode	Time			
			Speed			
		Tilt Movement range	Stand.			
			Reduc.			
	Microphone Sensitivity	1-10-20				
	Blackout Settings	Blackout During M.C.	Off, On			
		Blackout while:	Pan/Tilt moving	Off, On		
	Colour Calibration Mode	Off, On				
	Zoom Mode	Beam Zoom				
		Wash Zoom				
	LW Compatibility	Off, On				
	Init Effect Positions	Pan	0-255			
		:				
		Dimmer Fine	0-255			
	Screen Settings	Display Intensity	1-10			
		Screen Saver Delay	Off-10min.			
		Touchscreen Lock	Off-10min.			
		Recalibrate Touchscreen				
		Display Orientation	Normal			
			Inverted			
			Auto			
	Temperature Unit	°C, °F				
	Fan Mode	Auto				
		High				
	Theatre mode	On, Off				
	Date & Time Settings					
	Unlink Wireless Adapter *					
	Default Settings					
Manual Control	Reset Functions	Total System Reset				
		Pan/Tilt reset				
		Zoom Reset.				
	Preset Effect Control	Pan	Position 1-Position 5			
		:				
		Dimmer	Position 1- Position 5			
	Manual Effect Control	Pan	0-255			
		:				
		Dimmer Fine	0-255			
Stand -Alone	Test Sequences	Dynamic Mode				
		Static Mode	Pan	0-255		
			Tilt	0-255		
			Zoom	0-255		
	MusicTrigger	Off, On				
	Preset Playback	None				
		Test				
		:				
		Prog. 3				
	Play Program	Play Program 1				
		Play Program 2				

Tab	Level 1	Level 2	Level 3	Level 4	Level 5	Level 6
	Play Program 3					
	Edit Program	Edit Program 1	Start Step	1-100		
			End Step	1-100		
			Edit Program Steps	Step 1	Pan (0-255)	
				:	:	
				:	Dimmer Fine (0-255)	
				:	Step Time (0-25.5s)	
				Step 100	Pan (0-255)	
					:	
					Dimmer Fine (0-255)	
					Fade Time (0-25.5s)	
Service	Adjust DMX Values	Pan	0-255			
		:				
		Dimmer Fine	0-255			
	Calibrations	Calibrate Effects	Pan	0-255		
			Tilt	0-255		
		Calibrate colours	Red	0-255		
			Green	0-255		
			Blue	0-255		
			White	0-255		
		Load Default Calibrations				
	Update Software					

* Only for wireless DMX version

4.1 LED zone order

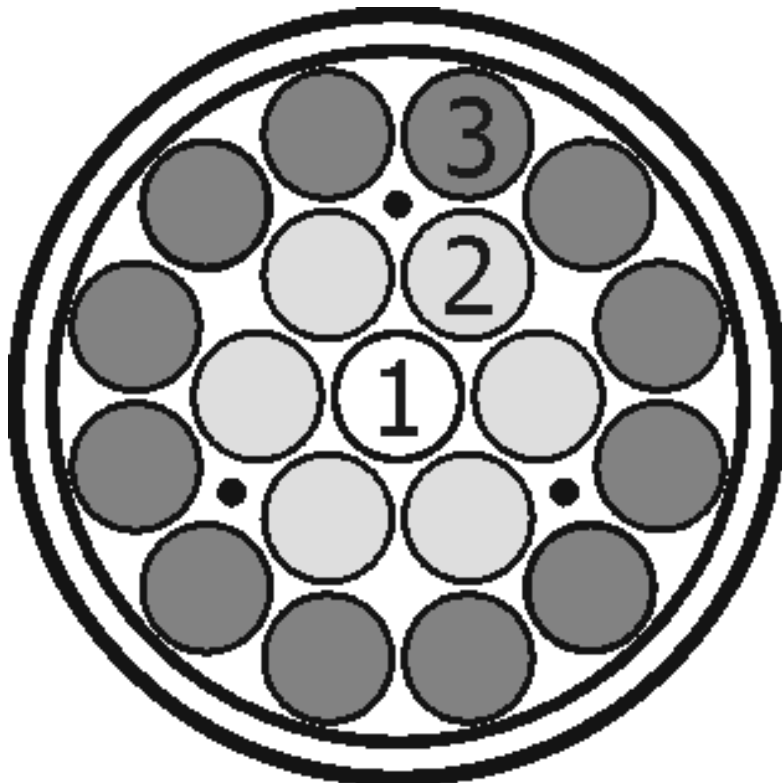

5. Control menu

The Robin 300X LEDWash equipped with the QVGA Robe touch screen with battery backup which allows to set the fixture's behaviour according to your needs, obtain information on its operation, test its various parts and lastly program it, if it has to be used in a stand-alone mode. The fixture's menu can be controlled either by the control buttons or directly by touching the icon.

Control buttons on the front panel:

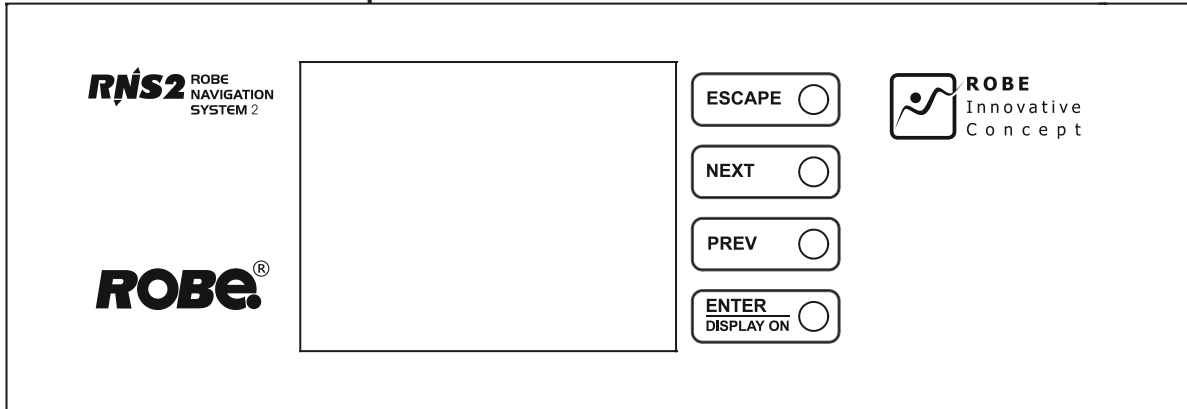

[ESCAPE] button used to leave the menu without saving changes.

[NEXT] , [PREV] buttons for moving between menu items and symbols, adjusting values.

[ENTER/Display On] button used to enter the selected menu (menu item) and to confirm adjusted value.

If the fixture is disconnected from mains, the button switches the touch screen on.

Icons used in the touch screen menu:

- [back arrow] used to move back to the previous screen (menu).
- [up arrow] used to move up on the previous page.
- [down arrow] used to move down on the next page.
- [confirm] used to save adjusted values, to leave menu or to perform desired action.
- [cancel] used to leave menu item without saving changes.
- [confirm+copy] used to save adjusted values and copy them to the next prog. step.
- [warning icon] used to indicate some error which has occurred in the fixture.
- [Ethernet] used to indicate Ethernet connected.
- [display turn] used to turn the display by 180°.

The menu page displays icons for each function that you can perform from the touch screen.

After switching the fixture on, the touch screen shows the screen with the ROBE logo:

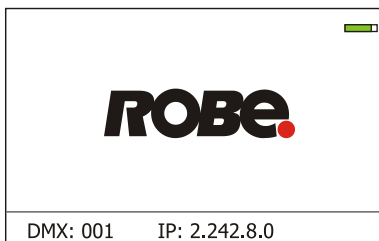

The green icon at the top right corner of the screen indicates the level of the display battery charging. If the whole icon is green, the battery is fully charged while the red icon indicates exhausted battery. The battery charges during fixture operation, its charging lasts cca 6 hours.

We recommend that the fixture should be in operation at least 7 hours per week to keep the battery fully charged.

If you switch the fixture on and this screen will not appear till 1 minute, switch the fixture off and on again. If the screen lights, the battery is exhausted. In case the screen still does not light, the battery is faulty.

Touch any part of the screen or press the [ENTER/Display On] button to display the initial screen with the current stored DMX address:

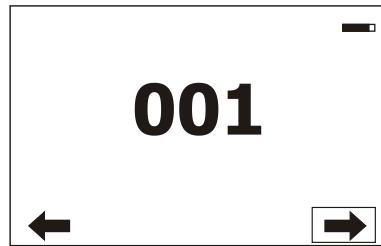

Touch the green arrow at the bottom right corner of the screen or press the [ENTER/Display On] button to enter the "Address" menu.

An item (such as a Tab, menu item, text box, icon) may be selected from a screen by simply touching the item in the list or by pressing the [NEXT] or [PREV] buttons to scroll through list items. With each press, the next item is highlighted. Press [ENTER/Display On] to select the highlighted item.

Before first fixture operation, set current date and time in the menu "Date & Time Settings" (menu path: Personality--> Date & Time Settings).

5.1 Tab "Address"



Settings - Select the menu to set desired fixture address setting.

DMX Address - Select the menu to set the DMX start address.

Ethernet Settings - The menu allows all needed settings for the Ethernet operation

Ethernet Mode - Use the menu to set the Ethernet operation mode:

Disable - The option disables Ethernet operation.

Artnet - Fixture receives Artnet protocol - every fixture has to be connected to the network.

gMAI - Fixture receives MANet protocol.

gMA2 - Fixture receives MANet2 protocol.

Art2DMX - Fixture receives Artnet protocol from the Ethernet input and sends DMX data to its DMX output (fixture works as an "Artnet/DMX converter", next fixture can be connected to its DMX output and you can build a standard DMX chain by connecting another fixtures. Only one fixture has to be connected to the Ethernet.

IP Address/Net Mask - Select this menu to set IP address. IP address is the Internet protocol address. The IP uniquely identifies any node (fixture) on a network. There cannot be 2 fixtures with the same IP address on the network!

Default IP Address - Preset IP address, you can set up only first byte of IP address (2 or 10) e.g. **002**.019.052.086.

Custom IP Address - The option enables to set up all bytes of IP address.

Net Mask - The option enables to set up all bytes of Net Mask.

ArtNet Universe - Use this item to set a Universe (0-255). The Universe is a single DMX 512 frame of 512 channels.

MANet Settings - Use this menu to set parameters for MANet operation.

MANet I/II Universe - The value of this item can be set in range 1-256.

MANet Session ID - The value of this item can be set in range 1-32.

5.2 Tab "Information"



Fixture Times - The menu provides readouts of fixture operation hours.

Power On Time Hours - Select this menu to read the number of fixture operation hours.

Total Hours - The item shows the total number of the operation hours since the Robin 300X LEDWash has been fabricated.

Resetable Hours - The item shows the number of the operation hours that the Robin 300X LEDWash has been powered on since the counter was last reset.
In order to reset this counter to 0, touch the text box next to the item "Resetable Hours:"

Fixture Temperatures - The menu is used to view temperatures of the fixture's inside.

LEDs Temperature - The menu shows temperatures in the LED module.

Current - A current temperature of the LED module.

Maximum NonRes. - A maximum temperature of the the LED module since the fixture has been fabricated.

Maximum Res. - A maximum temperature of the the LED module since the counter was last reset.

In order to reset this counter to 0, touch the text box next to the item "Maximum Res."

Ambient Temperature - The menu shows temperature of the induced air on the fan in the fixture base .

Current - A current temperature of the induced air in the fixture base.

Maximum NonRes. - A maximum temperature of the induced air in the fixture base since the fixture has been fabricated.

Maximum Res. - A maximum temperature of the induced air in the fixture base since since the counter was last reset.

In order to reset this counter to 0, touch the text box next to the item "Maximum Res."

Base Temperature - The menu shows temperature in the fixture base.

Current - A current temperature in the fixture base.

Maximum NonRes. - A maximum temperature in the fixture base since the fixture has been fabricated.

Maximum Res. - A maximum temperature in the fixture base since the counter was last reset.

In order to reset this counter to 0, touch the text box next to the item "Maximum Res."

DMX Values - The menu is used to read DMX values of each channel received by the fixture.

Wireless State - The menu serves for reading of the wireless operation status (only for Wireless DMX version).

Product IDs - The menu is used to read the MAC Address ,RDM UID and RDM Label.

Software Version - Select this item to read the software version of the fixture modules:

Display System - A display processor on the display board in the fixture base

Module M - A pan/Tilt processor on the main board in the fixture arm

Module L - Zoom and LED control processor on the board in the fixture head.

View Logs - Use this menu to read fixture's data which have been recorded during fixture operation. This collected data allows easier troubleshooting.

Fixture Errors - Use this menu to read fixture errors which have occurred during fixture operation.

Fixture States - Recorded following actions: Fixture On, Fixture Off.

Fixture Position - Recorded installation positions of the fixture:

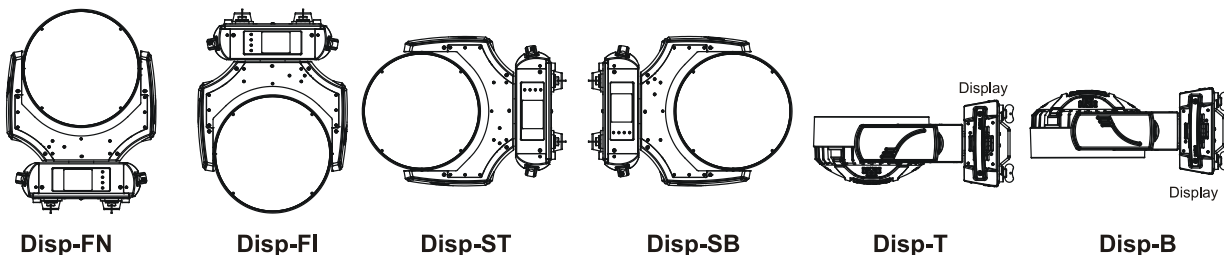

Fixture Temperatures - Recorded temperatures which have exceeded defined levels.

5.3 Tab "Personality"



User mode - The Robin 300X LED Wash allows you to recall up to 3 user settings. After switching the fixture on for the first time, the User A settings is active. Now all changes made in the "Personality" menu, "Addressing" menu and the "Music Trigger" and "Preset Playback" items from the "Stand-alone" menu are saved to the User A settings. If you now select the User B settings, from this moment the changes made in these menus will be saved to the User B settings. After switching the fixture off and on, the User B setting is active. In this way you may use the 3 fixture operating behaviours.

User A Settings - the function recalls the user A settings.

User B Settings - the function recalls the user B settings.

User C Settings - the function recalls the user C settings.

DMX Preset - Use the menu to select desired channel mode.

Mode 1 - 37 control channels

Mode 2 - 21 control channels

Mode 3 - 15 control channels

Mode 4 - 10 control channels

Mode 5 - 37 control channels

View Selected Preset - Use the menu to display channels included in the selected mode.

Pan/Tilt Settings - Use the menu set behaviour of both pan and tilt movements.

Pan Reverse - The item allows to invert pan movement.

Tilt Reverse - The item allows to invert tilt movement.

Pan/Tilt Feedback - The item allows to return the moving head to the required pan/tilt position after changing the position by an external force if this option is set on.

Note. Be careful, the Pan/Tilt Feedback should be permanent On, the option Off is not suitable for standard operation and the head of the fixture can be damaged!

Pan/Tilt mode - Use this menu to set the mode of the pan/tilt movement

Time mode – The pan and tilt will move with different speeds and they will come at the same time to the end point of their tracks (pan and tilt use their optimal speeds). Time of the pan/tilt movement (25.5 sec. max.) is set by the channel "Pan/Tilt speed, Pan/Tilt time".

Speed Mode - Both Pan and tilt will move with the same speed as adjusted at the channel "Pan/Tilt speed, Pan/Tilt time".

Tilt Movement Range - Use this menu to set the range of the tilt movement of the fixture's head

Stand. – Standard range 0-300°.

Reduc. - Reduced range of 0-210°. This option must be selected when the top hat is installed otherwise fixture's head runs into base.

Microphone Sensitivity - Enter the menu if you want to adjust the microphone sensitivity from 1 (max.) to 20 (min.).

Blackout Settings - Use the menu if you need to close the light output under certain conditions which are described below

Blackout DMC - Blackout during movement correction. Set this option On if you wish to close light output during the time when the head goes to its correct position, which has been changed by an external force.

Active Blackouts - Use this menu if you wish to close the light output during effect changes.

Pan/Tilt Moving - The menu item enables to close light output while the pan/tilt coordinates are changing.

Colour Calibration Mode - If the function is on, the white output from the fixture (and also mixed colours) is more uniform. Each colour is dynamically corrected according to the value set in the menu "Calibrate Effects" (Service-> Calibrations-> Calibrate Effects).

Zoom mode - Use this menu to change min. beam angle.

Beam Zoom - Beam angle 8°-53° (half beam)

Wash Zoom - Beam angle 15°-53° (half beam), compatible zoom range with the Robin LED Wash 300/600.

LW Compatibility - If the menu item is on, the colours on the Virtual colour wheel and mixed colours by means of RGBW channels approximate to the Robin 300 LEDWash/Robin 600 LEDWash (item Colour Calibration Mode has to be set On and the Zoom mode has to be set at Wash Zoom).

Init Effect Positions - Use the menu to set all effects to the desired positions at which they will stay after switching the fixture on without DMX signal connected.

Screen Settings - Use this menu to change the touch screen settings.

Display Intensity - The item allows to control the intensity of the screen (1-min., 10-max.).

Screen saver Delay - The item allows you to keep the screen on or to turn it off automatically after 1-10 minutes after last touch (or pressing any button on the control panel).

Touchscreen Lock - The item allows you to lock the screen after last touch (or pressing any button on the control panel). The time delay can be set in range of 1-10 minutes. To unlock the screen, press the [ENTER/Display On] button.

Recalibrate Touchscreen - The item starts calibration of the touchscreen. Follow the instructions on the screen.

Display Orientation - The menu allows to change display orientation.

Normal - Standard display orientation if the fixture is placed horizontally (e.g. on the ground).

Inverted - Inverted orientation (needed if the fixture is hanging on the truss).

Auto - The option activates a gravitation sensor for automatic screen orientation.

Note: **Auto** option is set as default. You change the display orientation by touching the icon  on the display, and the option set in the "Display Orientation" menu is temporarily overridden.

Temperature unit - Use the menu item to change temperature unit from °C to °F.

Fan Mode - Use the menu to set the fixture fans to max. fan power mode ("**High**") or to auto-control mode ("**Auto**").

Theatre mode - The mode reduces max. pan/tilt and zoom speed in order to provide silent operation of the fixture:

Pan range 0-450°: 3.4 seconds at max. speed.

Tilt range 0-300°: 2.5 seconds at max. speed.

Zoom min-max: 10 seconds at max speed

Date & Time Settings - Use this menu to set current date and time for the fixture log system (menu "**View Logs**"). Set this menu item before first fixture operation.

Unlink Wireless Adapter - The menu serves for unlinking the fixture from the transmitter (only WDMX version)

Default Settings - The menu item allows to set all fixture parameters to the default (factory) values.

5.4 Tab "Manual Control"



Reset Functions - The menu allows to reset the fixture either per function modules or all modules together.

Total System Reset - The item resets all function modules.

Pan/Tilt Reset - The item resets a pan and tilt movement.

Zoom Reset - The item resets a zoom module.

Preset Effect Control - Use the menu to show preset positions of each channel effect.

Manual Effect control - Use the menu to control all fixture channels by means of the control panel.

5.5 Tab "Stand-alone"



Test Sequences - Use the menu to run a test/demo sequences without an external controller, which will show you some possibilities of using Robin 300X LEDWash.

Dynamic Mode - This mode uses all Robin 300X LEDWash functions including pan/tilt movement and therefore is good for a complete introduction of the fixture.

Static Mode - This mode is suitable for projections on the wall, ceiling or ground without any pan/tilt movement. Adjust the pan, tilt and zoom to desired positions and start test sequences by touching the green ► icon.

Music Trigger - Use the item to activate the sound control of the running program via the built-in microphone.

Preset Playback - This menu allows you to select the program which will be played in a loop after switching the fixture on (the option is commonly used in a stand-alone operation without an external controller).

None - The option disables "Presetting playback" function.

Test - The option starts the test sequences.

Prog. 1 - The option starts user program No. 1.

Prog. 2 - The option starts user program No. 2.

Prog. 3 - The option starts user program No. 3.

Play program - Use the menu to run desired program in a loop.

Play Program 1 - The option starts user program No.1.

Play Program 2 - The option starts user program No. 2.

Play Program 3 - The option starts user program No. 3.

Edit Program - Use the menu to create or to edit desired program. The Robin 300X LEDWash offers 3 free programs, each up to 100 steps.

Edit Program 1 - The option allows to edit user program No.1.

Edit Program 2 - The option allows to edit user program No.2.

Edit Program 3 - The option allows to edit user program No.3

To edit program:

1. Touch the item which you want to edit ("Edit Program 1" - "Edit Program 3").

2. Touch the item "Edit Program Steps".

3. Touch the item "Step 1".

4. From the list of effects touch desired effect and set its value. Browse through the list by touching the [up arrow] and [down arrow] and set all desired effects.

An item "Step Time" (value of 0-25.5 sec.) is the time during which effects last in the current step

5. Save adjusted effects to the current step by touching the [confirm] or save and copy them to the following step by touching the [confirm+copy]. By touching the text box "Preview" next to the current program step you can view created scene.

6. Repeat the steps 4 and 5 for next program steps.

7. After editing desired program steps, adjust the length of the program by touching the text boxes "Start Step" and "End Step".

Meaning of the icons used in the "Edit Program" menu:

↓ - moves down on the next page

↑ - moves up on the previous page

✓ - saves adjusted values and leaves menu

✓ - saves values to the current step and copy them to the following prog. step

✗ - leaves menu without saving values

There is a chart describing behaviour of items "Pan/Tilt Macro" and "P./T. Macro Speed".

DMX	Pan/Tilt Macro
0 - 9	Disabled pan/tilt macro
10 - 31	Reserved
32 - 63	Figure of circle (from small to large)
64 - 95	Figure of horizontal eight (from small to large)
96 - 127	Figure of vertical eight (from small to large)
128 - 159	Figure of rectangle (from small to large)
160 - 191	Figure of triangle (from small to large)
192 - 223	Figure of star (from small to large)
224 - 255	Figure of cross (from small to large)
	Pan/Tilt Macro Speed
0	No macro generation
01 - 127	Macro generation from fast to slow-forwards
128 - 129	No macro generation
130 - 255	Macro generation from slow to fast-backwards

5.6 Tab "Service"



Adjust DMX Values - The menu allows you to set all effects to desired positions before fine calibration of the effects .

Calibrations - This menu enables fine calibration of fixture effects and download default calibration values.

Calibrate Effects - The menu allows the fine adjustment of effects.

Pan- a pan position fine adjustment

Tilt - a tilt position fine adjustment

Calibrate Colours - The menu serves for adjusting of LEDs saturation to achieve colour temperature of 5600K for white output.

Red - a red LEDs saturation fine adjustment

Green - a green LEDs saturation fine adjustment

Blue - a blue LEDs saturation fine adjustment

White - a white LEDs saturation fine adjustment

By using these items you can calibrate and adjust effects to desired positions.

Calibration of the pan/tilt via the control board

1. Disconnect DMX controller from the fixture and enter the "Calibrate Effects" menu.
2. Use the [up arrow] and [down arrow] to find "Pan" and touch it to enter the fine effect adjustment screen.
3. Set desired value and save it by touching the [confirm].
4. Repeat steps 2 and 3 for the item "Tilt".
5. After calibrating all effects, touch the [confirm] to save all adjusted values and reset the fixture.

Calibration of the colour saturations via the control board

1. Disconnect DMX controller from the fixture , open shutter and dimmer and set the Virtual colour wheel channel to DMX=10 (white 5600K). Aim the light beam on the lux meter (e.g. Minolta CL-500A Chroma meter) which is placed at min distance of 2.5m from the fixture
2. Set the menu item "Colour Calibration Mode" to On (Personality-> Colour Calibration Mode-> On).
3. Enter the menu "Calibrate Effects".
4. Use the [up arrow] and [down arrow] to find desired colour and touch it to enter the fine effect adjustment screen.
5. By means of the Red, green, Blue and White items adjust the 5600K colour temperature as exactly as possible ($\Delta u'v' = 0$).
7. After adjusting 5600K colour temperature, touch the [confirm] to save all adjusted values and reset the fixture.

Note: you can also use DMX controller for both calibrations stated above, calibration protocol is the following:

<i>Effect</i>	<i>Mode 1</i>	<i>Mode 2</i>	<i>Mode 3</i>	<i>Mode 4</i>	<i>Mode 5</i>
Pan-fine movement	channel 38	channel 22	channel 16	channel 11	channel 38
Tilt - fine movement	channel 39	channel 23	channel 17	channel 12	channel 39
Red - red saturation	channel 40	channel 24	channel 18	channel 13	channel 40
Green- green saturation	channel 41	channel 25	channel 19	channel 14	channel 41
Blue - blue saturation	channel 42	channel 26	channel 20	channel 15	channel 42
White - white saturation	channel 43	channel 27	channel 21	channel 16	channel 43

Load Default Calibrations - The item loads default (factory) calibration values.

Updating software - The menu item allows you to update software in the fixture via either serial or USB port of PC.

The following items are required in order to update software:

- PC running Windows or Linux or macOS
- DSU file
- Flash cable RS232/DMX (P/N13050624) or Robe Universal Interface / Robe Universal interface WTX.

To update software in the fixture:

1. DSU file is available from Robe web site at WWW.robe.cz.
File with extension zip is intended for Windows (used and tested from XP to W10 on 32/64bit systems).
File with extension tbz is intended for Linux (used and tested on Debian and Ubuntu 32/64bit).
File with extension dmg is intended for macOS (used and tested on OSX up to Sierra) XQuartz required, install it from <https://www.xquartz.org/>
Save the download file to a folder on your computer.
In case that you use windows, extract files in the zip file (e.g. DSU_Robin300XLEDWash_18042554.zip)
2. Disconnect the fixture from DMX controller.
3. If you use the flash cable RS232/DMX, connect a serial port of your computer with DMX input of the fixture by means of the cable (probably you will need some USB to RS 232 converter if your computer has USB ports only).
If you use the Robe Universal Interface, connect a USB port of your computer with the Robe Universal Interface by means of the USB cable and DMX input of the fixture with the DMX output of the Robe Universal Interface via a DMX cable.
4. Switch the fixture to the update mode (Tab "Service" --> Update software).
Note: If you do not want to continue in the software update, you have to switch off and on the fixture to escape from the updating mode.
We recommend to cancel all running programs on your computer before starting the software uploader.
5. Double-click the software uploader file (e.g. DSU_Robin300XLEDWash_18042554.exe) in the extracted files. The Software Uploader program will start running.

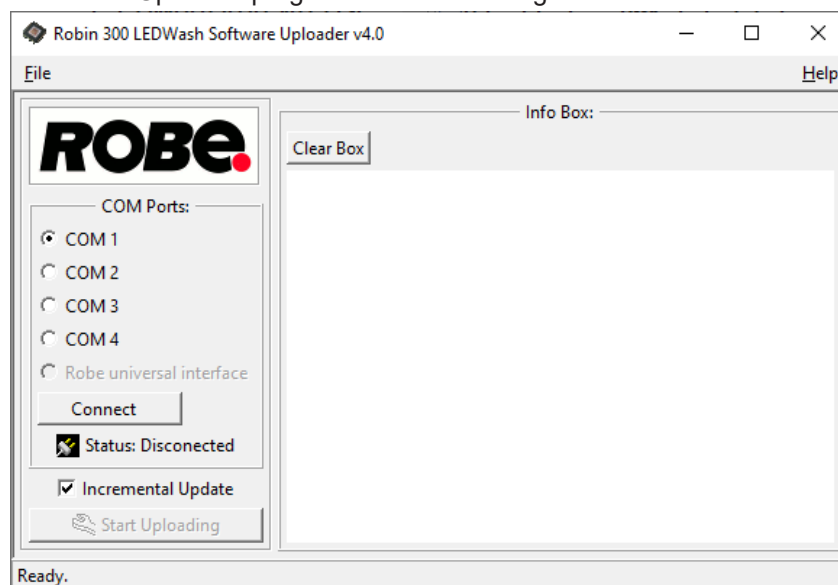

6. Select correct "COM " number if you use a Flash cable RS232/DMX or select "Robe Universal Interface 1 " if you use the Robe Universal Interface/Robe Universal Interface WTX and then click on the "Connect" button.
7. If the connection is OK, click the "Start Uploading" button to start software uploading. It will take several minutes to perform software update.

If the option "Incremental Update" is not checked, all processors will be updated (including processors with the same software version).

If you wish to update only processors with new version of software, check the "Incremental Update box".

Avoid interrupting the process. Update status is being displayed in the "Info Box" window.

When the update is finished, the line with the text "Fixture is successfully updated" will appear in this window.

Note: After all processors updating, the fixture will be set to default values. If you use the Incremental update, setting the fixture to default values depends on type of updated processors.

In case upload process is interrupted (e.g. power loss), the fixture stays in "Updating mode" and you will have to repeat the software update again.

Another way, how to update software in the fixtures (especially large installation of fixtures) is to use the ROBE Uploader. It is a software for automatized software update of Robe fixtures. It can take advantage of RDM support and Ethernet ports if present in the units.

For more information please see <https://www.robe.cz/robe-uploader/>.

6. RDM

This fixture supports RDM operation. RDM (Remote Device Management) is a bi-directional communications protocol for use in DMX512 control systems, it is the new open standard for DMX512 device configuration and status monitoring.

The RDM protocol allows data packets to be inserted into a DMX512 data stream without adversely affecting existing non-RDM equipment. By using a special „Start Code,“ and by complying with the timing specifications for DMX512, the RDM protocol allows a console or dedicated RDM controller to send commands to and receive messages from specific moving lights.

RDM allows explicit commands to be sent to a device and responses to be received from it.

The list of commands for Robin 300X LEDWash is the following.

Parameter ID	Discovery command	SET command	GET command
DISC_UNIQUE_BRANCH	*		
DISC_MUTE	*		
DISC_UN_MUTE	*		
DEVICE_INFO			*
SUPPORTED_PARAMETERS			*
SOFTWARE_VERSION_LABEL			*
DMX_START_ADDRESS		*	*
IDENTIFY_DEVICE		*	*
DEVICE_MODEL_DESCRIPTION			*
MANUFACTURER_LABEL			*
DEVICE_LABEL		*	*
SENSOR_DEFINITION			*
SENSOR_VALUE			*
DISPLAY_INVERT		*	*
DISPLAY_LEVEL		*	*
PAN_INVERT		*	*
TILT_INVERT		*	*
DEVICE_RESET		*	
DMX_PERSONALITY		*	*
DMX_PERSONALITY_DESCRIPTION			*

STATUS_MESSAGES			*
STATUS_ID_DESCRIPTION			*
DEVICE_HOURS ²			*

7. Wireless DMX operation

The wireless version of the Robin 300X LEDWash is equipped with the Lumen Radio CRMX module and antenna for receiving DMX signal. CRMX module operates on the 2.4 GHz band.

To link the fixture with DMX transmitter.

The fixture can be only linked with the transmitter by running the link procedure at DMX transmitter .

After linking , the level of DMX signal (0-100 %) is displayed in the menu item “Wireless State“ (Information -->Wireless State)

To unlink the fixture from DMX transmitter.

The fixture can be unlinked from receiver via the menu item “ Unlink Wireless Adapter“ (Personality--> Unlink Wireless Adapter.).

8. Error and information messages

Occurred errors during fixture operation are signalled by the yellow warning icon at the bottom line of the screen:



Touch the warning icon or press the [ESCAPE] button to display error messages.

List of error and information messages:

Temper.Sensor Error

The message informs you that the communication between the head temperature sensor and the main processor failed.

Tilt Error 1 (Tilt Error 2)

This message will appear after the reset of the fixture if the head’s magnetic-indexing circuit malfunctions (sensor failed or magnet is missing) or the stepping motor is defective or its driving IC on the PCB. The head is not located in the default position after the reset.

Pan Error 1 (Pan Error 2)

This message will appear after the reset of the fixture if the yoke’s magnetic-indexing circuit malfunctions (sensor failed or magnet is missing) or the stepping motor is defective or its driving IC on the PCB. The yoke is not located in the default position after the reset of the fixture.

9. Technical Specifications

Electrical

Power supply:.....electronic auto-ranging
Input voltage range:..... supply 100-240V, 50/60Hz
Fuse:.....T3.15 A
Max. power consumption:.....200W (power factor=0.96)

Optic

Light source: 19 Osram Ostar RGBW multichips
3 LED zones with individual colour control of each
Typical Lumen Maintenance: 70% @ 60,000 hours
LED life expectancy: 60.000 hours
RGBW colour mixing +CTC
Beam angle range: 8°-63°

Virtual colour wheel

237 colours including whites (2700K, 3200K, 4200K, 5600K and 8000K)
Halogen lamp effect at whites 2700K and 3200K
Rainbow effect with in both directions with variable speed
Zone effects in both directions with variable speed

Strobe

All LED zones together:
 Strobe effect with variable speed (0.3 - 20Hz)
 Random strobe pulse-effect with variable speed
 Opening/closing pulse effect with variable speed
Independent strobe effect with variable speed (0.3 - 20Hz) at LED zone 3
Random strobe and random LED zone effect

Dimmer

Smooth dimmer from 0 - 100 %

Zoom

Motorized
Beam mode: 8°-53° (at half beam)
Zoom mode: 15°-53°(at half beam)

Pan/Tilt

Pan movement range: 450°
Tilt movement range: 300°
16 bit movement resolution
Automatic Pan/Tilt position correction
Remotely controllable speed of pan/tilt movement for easy programming
Pan movement 0° - 450° at max. speed: 1.8 sec. (3.4 sec. - Theatre mode)
Tilt movement 0° - 300° at max. speed: 0.9 sec. (2.7 sec. - Theatre mode)

Control

Graphic touch screen for fixture setting and addressing
Gravitation sensor for auto screen positioning
Battery backup of the touch screen
Readout fixture usage, receiving DMX values, temperatures, etc
Built-in analyzer for easy fault finding, error messages
Built-in demo sequences
Theatre mode for silent pan/tilt and zoom moving
Silent fans cooling,
Stand-alone operation

3 user editable programs, each up to 100 steps
Supported protocols: USITT DMX 512, RDM, ArtNet, MANet, MANet2
Support of RDM (Remote Device Management)
5 DMX modes (37, 21, 15, 10, 37 control channels)

Wireless DMX/RDM module (only for Wireless DMX version)

Compliance with USITT DMX-512 (1986 & 1990) and 512-A
Full DMX fidelity and frame integrity
Auto sensing of DMX frame rate and frame size
<5ms DMX latency
Operational frequency range of 2402-2480 MHz
Producer: LumenRadio

Connection

DMX data in/out: Locking 3-pin and 5-pin XLR
AC power input: Chassis connector Neutrik PowerCon TRUE 1, NAC3MPX
Ethernet: RJ45

Rigging

Mounting points: 2 pairs of 1/4-turn locks
Mounting horizontally or vertically via 2 Omega brackets

Temperatures

Maximum ambient temperature : 45° C
Maximum housing temperature : 75° C

Minimum distances

Min. distance from flammable surfaces: 0.25 m
Min. distance to lighted object: 0.8 m

Total heat dissipation

685 BTU/h (calculated)

Weight (net):

8.2 kg

Dimensions (mm)

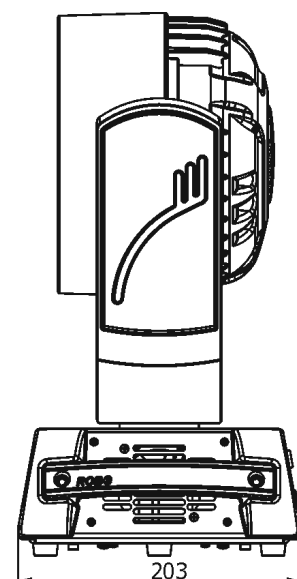
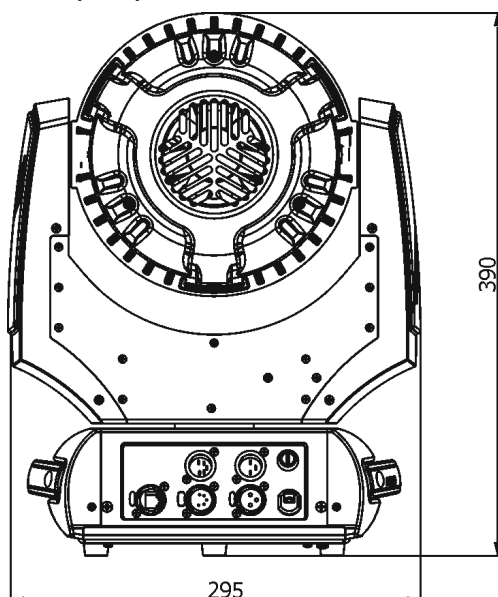

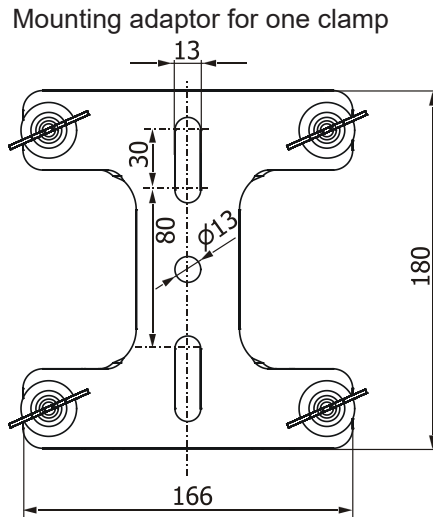

Accessories

- 1 x Mounting Adaptor for one clamp (black) (P/N 99013318)
- 1 x Power cable including powerCON TRUE1 In connector

Optional accessories

- Top Hat ROBIN 300 LEDWash (black) (P/N 10980102)
- Top Hat ROBIN 300 LEDWash (white) (P/N 10980104)
- EggCrate ROBIN 300 LEDWash/Actor 3 (transparent) (P/N 1098 0115)
- Mounting Adaptor for one clamp (black) (P/N 10980100)
- Doughty Trigger Clamp (P/N 17030386)
- Safety wire 35 kg (P/N 99011963)
- Upgrade kit CRMX Univerzal 150 (P/N 99030099)

10. Maintenance and cleaning

It is absolutely essential that the fixture is kept clean and that dust, dirt and smoke-fluid residues must not build up on or within the fixture. Otherwise, the fixture's light output will be significantly reduced. Regular cleaning will not only ensure the maximum light output, but will also allow the fixture to function reliably throughout its life. A soft lint-free cloth moistened with any weak detergent solution is recommended for cleaning fixture's covers, under no circumstances should alcohol or solvents be used!

DANGER !
Disconnect from the mains before starting any maintenance and cleaning work

The interior of the fixture should be cleaned at least annually using a vacuum cleaner or compressed air. The cooling fans should be cleaned at least twice a year.

Important! Never use alcohols (ethanol, methanol, isopropyl alcohol), acetone and another aggressive solvents for cleaning the front transparent cover.

Recommended steps for cleaning the front transparent cover:

1. Use low-pressure compressed air to remove coarse dust from the transparent cover.
2. Use distilled water with weak detergent solution and lint-free small cloth for further cleaning of the transparent cover.
3. Use an antistatic, alcohol-free screen cleaner (we recommend the Lyreco Screen Cleaner) and polish the transparent cover until it is dry.
4. Check the transparent cover is dry before reapplying power.

Checking plastic parts of the fixture.

The plastic parts of the fixture should be checked for damages and beginning cracks at least every two months. If hint of a crack is found on some plastic part, do not use the fixture until the damaged part will be replaced. Cracks or another damages of the plastic parts can be caused by the fixture transportation or manipulation and also ageing process may influence plastic materials.

This checking is necessary for both fixed installations and preparing fixtures for renting. Any free moving parts inside of the fixture head, cracked plastic or any plastic part not sitting properly in place need to be immediately replaced.

More complicated maintenance and service operations are only to be carried out by authorized distributors.

10.1 Replacing fuse

Only replace the fuse by a fuse of the same type and rating.

Before replacing the fuse, unplug mains lead!

If you need to replace the main fuse, follow the instructions:

1. Remove the fuse holder on the rear panel of the base with a fitting screwdriver from the housing (anti-clockwise).
2. Remove the old fuse from the fuse holder.
3. Install the new fuse in the fuse holder (only the same type and rating).
4. Replace the fuse holder to the rear panel and fix it.

11. Photometric diagrams

Min. Zoom (Beam mode)

Total Output: 2412 lumens

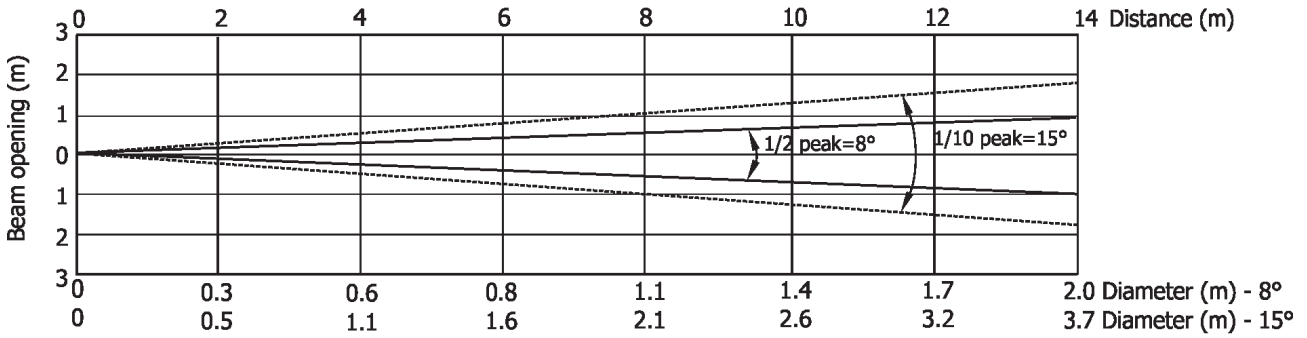

Distance (m)	2	4	5	6	8	10	12	14	
Red	7263/675	1815/169	1162/108	807/75	454/42	290/27	202/19	148/14	Intensity (center) Lux/Footcandles
Green	15300/1421	3825/355	2448/227	1700/158	956/89	612/57	425/40	312/29	
Blue	2762/257	690/64	442/41	307/29	173/16	110/10	77/7.1	56/5.2	
White	19875/1846	4969/462	3180/295	2208/205	1242/115	795/74	552/51	406/38	
R+G+B+W	30594/2842	7648/710	4895/455	3399/316	1912/178	1224/114	850/79	624/58	

Illuminance distribution

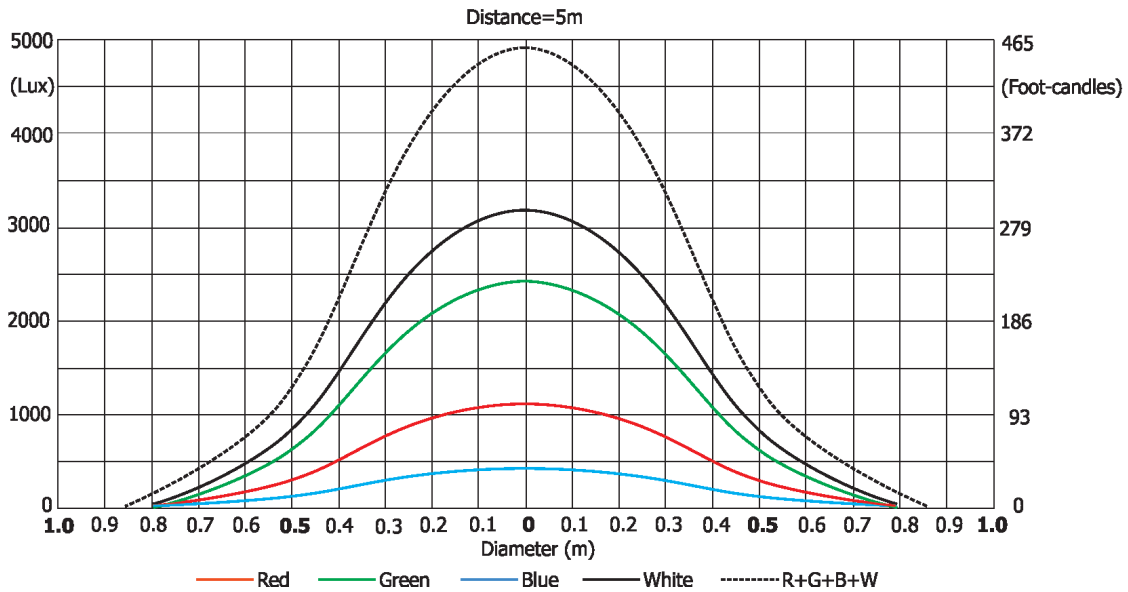

May 30 2022

Copyright © 2019-2022 Robe Lighting - All rights reserved

All Specifications subject to change without notice

Made in CZECH REPUBLIC by ROBE LIGHTING s.r.o. Palackeho 416/20 CZ 75701 Valasske Mezirici

Min. Zoom (Wash mode)

Total Output: 2886 lumens

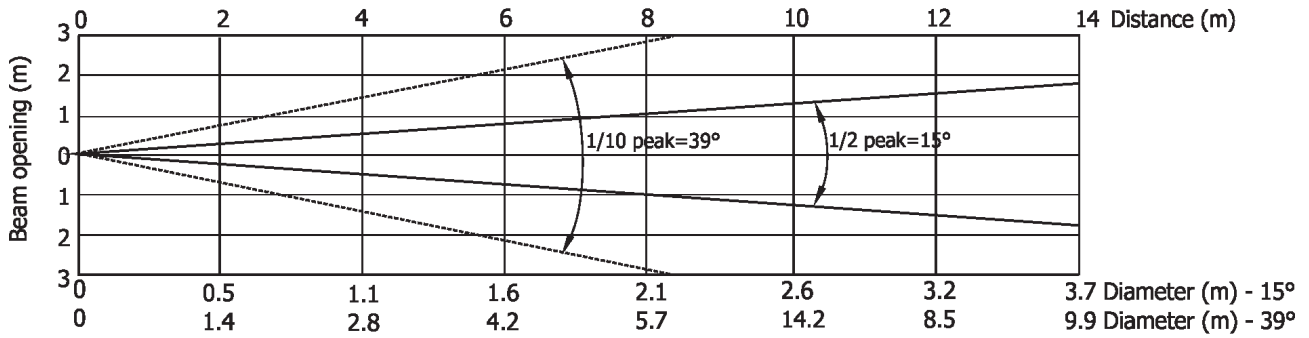

Distance (m)	2	4	5	6	8	10	12	14	
Red	6300/585	1575/146	1008/94	700/65	394/37	252/23	175/16	129/12	Intensity (center) Lux/Footcandles
Green	12800/1189	3200/297	2048/190	1422/132	800/74	512/48	355/33	260/24	
Blue	2481/230	620/58	397/37	276/26	155/14	99/9	69/6	50/5	
White	15300/1421	3825/355	2448/227	1700/158	956/89	612/57	425/40	312/29	
R+G+B+W	28925/2687	7231/672	4628/430	3214/299	1809/168	1157/108	803/75	590/55	

Illuminance distribution

Distance=5m

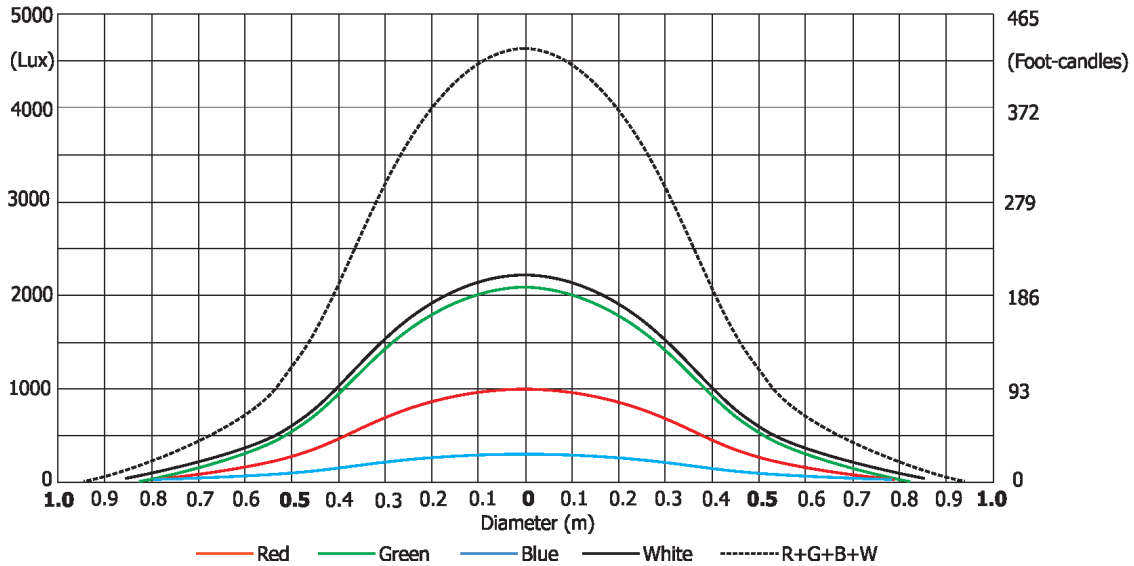

Max. zoom
Total Output: 4479 lumens

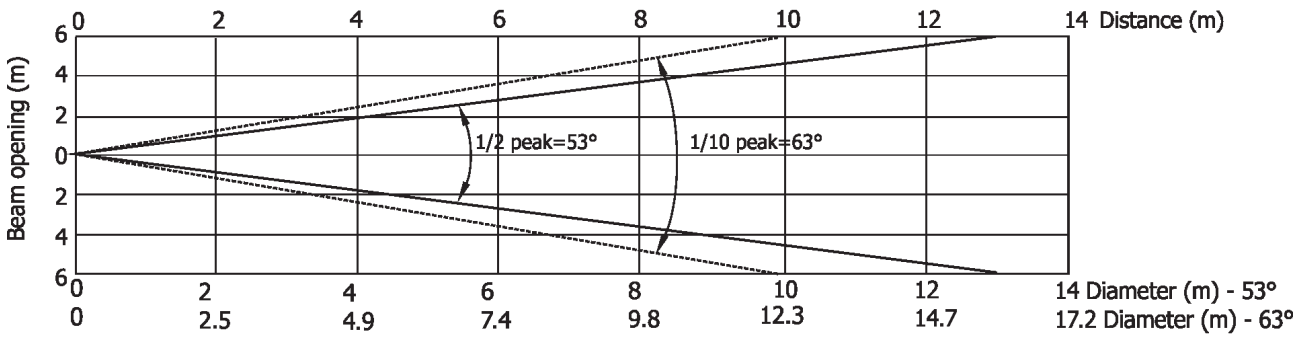

Distance (m)	2	4	5	6	8	10	12	14	
Red	425/40	106/10	68/6	47/4.4	27/2.5	17/1.6	12/1.1	9/0.8	Intensity (center) Lux/Footcandles
Green	943/88	236/22	151/14	105/10	59/5.5	38/3.5	26/2.4	19/1.8	
Blue	194/18	48/4.5	31/2.9	22/2.0	12/1.1	8/0.7	5/0.5	4/0.4	
White	1387/129	347/32	222/21	154/14	87/8	56/5	39/3.6	28/2.6	
R+G+B+W	1863/173	465/43	298/28	207/19	116/11	75/7	52/5	38/3.5	

Illuminance distribution

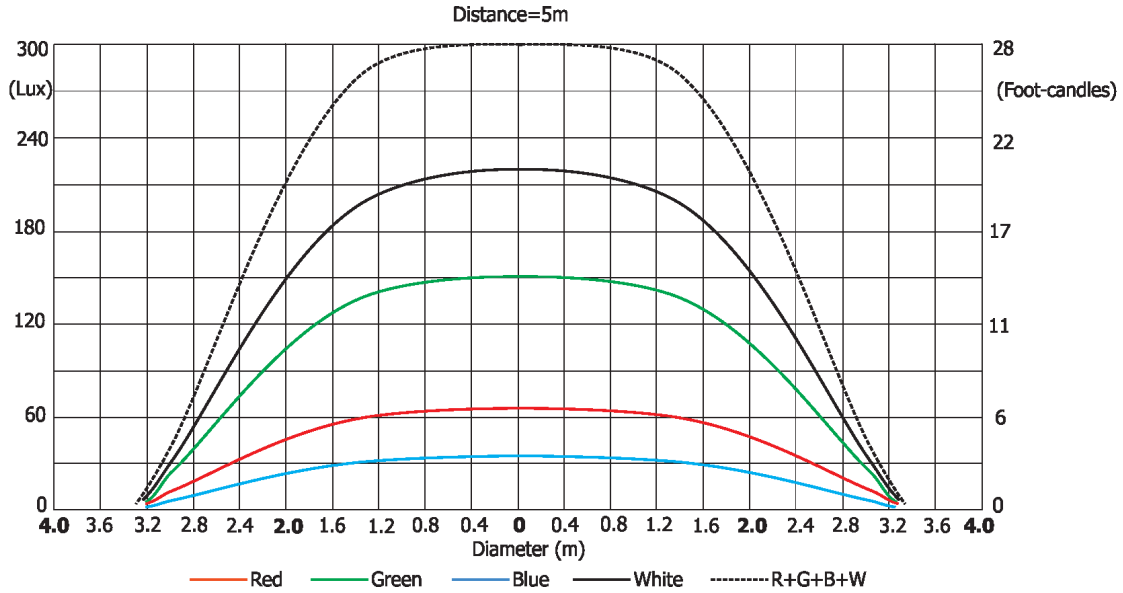

DMX protocol

Robin 300X LEDWash - DMX protocol, version 1.1							
Mode/Channel					Value	Function	Type of control
1	2	3	4	5			
1	1	1	1	1	0-255	Pan (8 bit) Pan movement by 450° (128=default)	proportional
2	2	2	2	2	0-255	Pan Fine (16 bit) Fine control of pan movement (0=default)	proportional
3	3	3	3	3	0-255	Tilt (8bit) Tilt movement by 300° (128=default)	proportional
4	4	4	4	4	0-255	Tilt fine (16 bit) Fine control of tilt movement (0=default)	proportional
5	5	5	5	5		Pan/Tilt speed, Pan/Tilt time	
					0	Standard mode (0=default)	step
					1	Max. speed mode	step
					2 - 255	<i><u>P./T. speed</u> -set Speed Mode in menu: P./T. Mode</i> Speed from max. to min. (vector mode)	proportional
					2 - 255	<i><u>P./T. time</u> - set Time Mode in menu: Pan/Tilt Mode</i> Time from 0.2 s to 25.5 s.	proportional
6	6	6	6	6		Special functions	
					0 - 49	Reserved (0=default)	
						<i>To activate following functions , stop in DMX value for at least 3sec. and shutter must be closed at least 3sec. (Shutter channel 35/19/14/9/9/22 must be at range of 0-31DMX). Corresponding menu items are temporarily overridden.</i>	
					50 - 59	Pan/Tilt speed mode	step
					60 - 69	Pan/Tilt time mode	step
					70 - 79	Blackout while pan/tilt moving	step
					80 - 89	Disabled blackout while pan/tilt moving	step
					90 - 99	Theatre mode On	step
					100-109	Theatre mode Off	step
					110-119	Reserved	
					120-124	LEDWash compatibility On	step
					125-129	LEDWash compatibility Off	step
					130-139	Reserved	
						<i>To activate following reset function, stop in DMX value for at least 3 sec.</i>	
					140 - 149	Pan/Tilt reset	step
					150 - 179	Reserved	
180 - 189	Zoom reset	step					
190 - 199	Reserved						
200 - 209	Total reset	step					
210 - 255	Reserved						
*	7	7	*	*	0-255	Red (8 bit) - all zones Red LEDs saturation control 0-100% (255=default)	proportional
*	8	*	*	*	0-255	Red fine(16 bit) - all zones Fine red LEDs saturation control (255=default)	proportional

DMX protocol

Mode/Channel					Value	Function	Type of control
1	2	3	4	5			
*	9	8	*	*	0-255	Green (8 bit) - all zones Green LEDs saturation control 0-100% (255=default)	proportional
*	10	*	*	*	0-255	Green fine (16 bit) - all zones Fine green LEDs saturation control (255=default)	proportional
*	11	9	*	*	0-255	Blue (8 bit) - all zones Blue LEDs saturation control 0-100% (255=default)	proportional
*	12	*	*	*	0-255	Blue fine (16 bit) - all zones Fine blue LEDs saturation control (255=default)	proportional
*	13	10	*	*	0-255	White (8 bit) - all zones White LEDs saturation control 0-100% (255=default)	proportional
*	14	*	*	*	0-255	White fine (16 bit) - all zones Fine white LEDs saturation control (255=default)	proportional
7	*	*	*	14	0-255	Red (8 bit) - zone 1 Red LEDs saturation control 0-100% (255=default)	proportional
8	*	*	*	15	0-255	Red fine (16 bit) - zone 1 Fine red LEDs saturation control (255=default)	proportional
9	*	*	*	16	0-255	Green (8 bit) - zone 1 Green LEDs saturation control 0-100% (255=default)	proportional
10	*	*	*	17	0-255	Green fine (16 bit) - zone 1 Fine green LEDs saturation control (255=default)	proportional
11	*	*	*	18	0-255	Blue (8 bit) zone 1 Blue LEDs saturation control 0-100% (255=default)	proportional
12	*	*	*	19	0-255	Blue (16 bit) zone 1 Fine blue LEDs saturation control (255=default)	proportional
13	*	*	*	20	0-255	White (8 bit) - zone 1 White LEDs saturation control 0-100% (255=default)	proportional
14	*	*	*	21	0-255	White (16 bit) - zone 1 Fine white LEDs saturation control (255=default)	proportional
15	*	*	*	22	0-255	Red (8 bit) - zone 2 Red LEDs saturation control 0-100% (255=default)	proportional
16	*	*	*	23	0-255	Red fine (16 bit) - zone 2 Fine red LEDs saturation control (255=default)	proportional
17	*	*	*	24	0-255	Green (8 bit) - zone 2 Green LEDs saturation control 0-100% (255=default)	proportional
18	*	*	*	24	0-255	Green fine (16 bit) - zone 2 Fine green LEDs saturation control (255=default)	proportional
19	*	*	*	26	0-255	Blue (8 bit) - zone 2 Blue LEDs saturation control 0-100% (255=default)	proportional
20	*	*	*	27	0-255	Blue fine (16 bit) - zone 2 Fine blue LEDs saturation control (255=default)	proportional
21	*	*	*	28	0-255	White (8 bit) - zone 2 White LEDs saturation control 0-100% (255=default)	proportional
22	*	*	*	29	0-255	White (16 bit) - zone 2 Fine white LEDs saturation control (255=default)	proportional
23	*	*	*	30	0-255	Red (8 bit) - zone 3 Red LEDs saturation control (0-100%) (255=default)	proportional

DMX protocol

Mode/Channel					Value	Function	Type of control
1	2	3	4	5			
24	*	*	*	31		Red fine (16 bit) - zone 3	
					0-255	Fine red LEDs saturation control (255=default)	proportional
25	*	*	*	32		Green (8 bit) - zone 3	
					0-255	Green LEDs saturation control 0-100% (255=default)	proportional
26	*	*	*	33		Green fine (16 bit) - zone 3	
					0-255	Fine green LEDs saturation control (255=default)	proportional
27	*	*	*	34		Blue (8 bit) zone 3	
					0-255	Blue LEDs saturation control 0-100% (255=default)	proportional
28	*	*	*	35		Blue fine (16 bit) zone 3	
					0-255	Fine blue LEDs saturation control (255=default)	proportional
29	*	*	*	36		White (8 bit) zone 3	
					0-255	White LEDs saturation control 0-100% (255=default)	proportional
30	*	*	*	37		White fine (16 bit) zone 3	
					0-255	Fine white LEDs saturation control (255=default)	proportional
31	15	11	*	12		CTC	
					0	No function (0=default)	step
					1-255	Colour temperature correction from 20000K to 2700K (<i>menu item "Colour Calibration Mode"=Off</i>)	proportional
					1-255	Colour temperature correction from 15500K to 2700K (<i>menu item "Colour Calibration Mode"=On</i>)	proportional
32	16	12	7	13		Virtual Colour Wheel	
						For detailed description see " Virtual colour wheel- colour mixing chart	
					0	No function (0=default)	step
					1-2	White 2700 K	step
					3	White 2700 K (Halogen lamp mode**)	step
					4-5	White 3200 K	step
					6	White 3200 K (Halogen lamp mode**)	step
					7-9	White 4200 K	step
					10-12	White 5600 K	step
					13-15	White 8000 K	step
					16	Blue (Blue=full, Red+Green+White=0)	step
					17-55	Red=0, Green->up,Blue =full, White=0	proportional
					56	Light Blue (Red=0, Green=full, Blue =full, White=0)	step
					57 - 95	Red=0, Green=full, Blue->down, White=0	proportional
					96	Green (Red=0, Green=full, Blue =0, White=0)	step
					97 – 134	Red->up, Green=full, Blue=0, White=0	proportional
					135	Yellow (Red=full, Green=full, Blue=0, White=0)	step
					136 - 174	Red=full, Green->down, Blue=0, White=0	proportional
					175	Red(Red=full, Green=0, Blue=0, White=0)	step
					176 -214	Red=full, Green=0, Blue->up, White=0	proportional
215	Magenta (Red=full, Green=0, Blue=full, White=0)	step					
216 - 246	Red -> down, Green=0, Blue=full, White=0	proportional					
247	Blue (Red=0, Green=0, Blue=full, White=0)	step					
		<i>Speed of the following effects can be controlled by the Shutter/Strobe channel (DMX values of 96-127)</i>					
248		Rainbow effect (with fade time)	step				

DMX protocol

Mode/Channel					Value	Function	Type of control
1	2	3	4	5			
					249	Rainbow effect	step
					250-255	Zone effect	step
33	17	13	8	7		Zoom (8 bit)	
					0 - 255	Zoom from min. to max. beam angle ((128=default)	proportional
34	18	*	*	8		Zoom fine (16 bit)	
					0 - 255	Fine zooming from min. to max. (0=default)	proportional
						Shutter/Strobe	
					0-31	Shutter closed	step
					32-63	Strobe effect from slow--> fast (zone 3 only) (32=default)	proportional
					64-95	Strobe effect from slow--> fast (All zones together)	proportional
						<i>Set value on Virtual colour wheel for zone effects</i>	
					96-111	Zone effect+rainbow effects speed control, slow--> fast	proportional
					112-127	Zone effect+rainbow effects speed control, fast--> slow /opposite direction/	proportional
35	19	14	9	9	128-143	Opening pulses in sequences from slow--> fast	proportional
						(All zones together)	
					144-159	Closing pulses in sequences from fast--> slow	proportional
						(All zones together)	
					160-175	Random strobe effect from slow--> fast (random zone)	proportional
					176-191	Random strobe effect from slow--> fast (random zone + random strobe)	proportional
					192-223	Random strobe effect from slow --> fast (All zones together)	proportional
					224-255	Shutter open	step
36	20	15	10	10		Dimmer (8 bit)	
					0-255	Dimmer intensity from 0% to 100% (0=default)	proportional
37	21	*	*	11		Dimmer fine (16 bit)	
					0-255	Fine dimming (0=default)	proportional
Copyright © 2019 -2020Robe Lighting s.r.o. - All rights reserved							
All Specifications subject to change without notice							

Robin 300X LEDWash - Virtual Colour Wheel

Scale*	Virtual Colour Wheel DMX	Red DMX	Green DMX	Blue DMX	White DMX
	1-2 (White 2700K)	255	158	0	53
	3 (White 2700K /Hal.mode/)	255	158	0	53
	4-5 (White 3200K)	255	173	0	102
	6 (White 3200K /Hal.mode/)	255	173	0	102
	7-9 (White 4200K)	255	197	0	255
	10-12 (White 5600K)	233	255	35	255
	13-15 (White 8000K)	162	255	63	255
	16	0	0	255	0
	17	0	3	255	0
	18	0	6	255	0
	19	0	9	255	0
	20	0	12	255	0
	21	0	15	255	0
	22	0	18	255	0
	23	0	21	255	0
	24	0	24	255	0
	25	0	27	255	0
	26	0	30	255	0
	27	0	36	255	0
	28	0	41	255	0
	29	0	46	255	0
	30	0	52	255	0
	31	0	58	255	0
	32	0	64	255	0
	33	0	68	255	0
	34	0	74	255	0
	35	0	80	255	0
	36	0	86	255	0
	37	0	92	255	0
	38	0	98	255	0
	39	0	104	255	0
	40	0	110	255	0
	41	0	119	255	0
	42	0	129	255	0
	43	0	138	255	0
	44	0	147	255	0
	45	0	156	255	0
	46	0	165	255	0
	47	0	174	255	0
	48	0	183	255	0
	49	0	192	255	0
	50	0	201	255	0
	51	0	210	255	0
	52	0	219	255	0
	53	0	228	255	0
	54	0	237	255	0
	55	0	246	255	0
	56	0	255	255	0
	57	0	255	246	0
	58	0	255	237	0
	59	0	255	228	0
	60	0	255	219	0
	61	0	255	210	0
	62	0	255	201	0
	63	0	255	192	0

Robin 300X LEDWash - Virtual Colour Wheel

Scale*	Virtual Colour Wheel	Red	Green	Blue	White
	DMX	DMX	DMX	DMX	DMX
	64	0	255	183	0
	65	0	255	174	0
	66	0	255	165	0
	67	0	255	156	0
	68	0	255	147	0
	69	0	255	138	0
	70	0	255	129	0
	71	0	255	119	0
	72	0	255	110	0
	73	0	255	104	0
	74	0	255	98	0
	75	0	255	92	0
	76	0	255	86	0
	77	0	255	80	0
	78	0	255	74	0
	79	0	255	68	0
	80	0	255	64	0
	81	0	255	58	0
	82	0	255	52	0
	83	0	255	46	0
	84	0	255	41	0
	82	0	255	36	0
	86	0	255	30	0
	87	0	255	27	0
	88	0	255	24	0
	89	0	255	21	0
	90	0	255	18	0
	91	0	255	15	0
	92	0	255	12	0
	93	0	255	9	0
	94	0	255	6	0
	95	0	255	3	0
	96	0	255	0	0
	97	3	255	0	0
	98	6	255	0	0
	99	9	255	0	0
	100	12	255	0	0
	101	15	255	0	0
	102	18	255	0	0
	103	21	255	0	0
	104	24	255	0	0
	105	27	255	0	0
	106	30	255	0	0
	107	36	255	0	0
	108	41	255	0	0
	109	46	255	0	0
	110	52	255	0	0
	111	58	255	0	0
	112	64	255	0	0
	113	68	255	0	0
	114	74	255	0	0
	115	80	255	0	0
	116	86	255	0	0
	117	92	255	0	0
	118	98	255	0	0

Robin 300X LEDWash - Virtual Colour Wheel

Scale*	Virtual Colour Wheel	Red	Green	Blue	White
	DMX	DMX	DMX	DMX	DMX
	119	104	255	0	0
	120	110	255	0	0
	121	119	255	0	0
	122	129	255	0	0
	123	138	255	0	0
	124	147	255	0	0
	125	156	255	0	0
	126	165	255	0	0
	127	174	255	0	0
	128	183	255	0	0
	129	192	255	0	0
	130	201	255	0	0
	131	210	255	0	0
	132	219	255	0	0
	133	228	255	0	0
	134	240	255	0	0
	135	255	255	0	0
	136	255	246	0	0
	137	255	237	0	0
	138	255	228	0	0
	139	255	219	0	0
	140	255	210	0	0
	141	255	201	0	0
	142	255	192	0	0
	143	255	183	0	0
	144	255	174	0	0
	145	255	165	0	0
	146	255	156	0	0
	147	255	147	0	0
	148	255	138	0	0
	149	255	129	0	0
	150	255	119	0	0
	151	255	110	0	0
	152	255	104	0	0
	153	255	98	0	0
	154	255	92	0	0
	155	255	86	0	0
	156	255	80	0	0
	157	255	74	0	0
	158	255	68	0	0
	159	255	64	0	0
	160	255	58	0	0
	161	255	52	0	0
	162	255	46	0	0
	163	255	41	0	0
	164	255	36	0	0
	165	255	30	0	0
	166	255	27	0	0
	167	255	24	0	0
	168	255	21	0	0
	169	255	18	0	0
	170	255	15	0	0
	171	255	12	0	0
	172	255	9	0	0
	173	255	6	0	0

Robin 300X LEDWash - Virtual Colour Wheel

Scale*	Virtual Colour Wheel	Red	Green	Blue	White
	DMX	DMX	DMX	DMX	DMX
	174	255	3	0	0
	175	255	0	0	0
	176	255	0	3	0
	177	255	0	6	0
	178	255	0	9	0
	179	255	0	12	0
	180	255	0	15	0
	181	255	0	18	0
	182	255	0	21	0
	183	255	0	24	0
	184	255	0	27	0
	185	255	0	30	0
	186	255	0	36	0
	187	255	0	41	0
	188	255	0	46	0
	189	255	0	52	0
	190	255	0	58	0
	191	255	0	64	0
	192	255	0	68	0
	193	255	0	74	0
	194	255	0	80	0
	195	255	0	86	0
	196	255	0	92	0
	197	255	0	98	0
	198	255	0	104	0
	199	255	0	110	0
	200	255	0	119	0
	201	255	0	129	0
	202	255	0	138	0
	203	255	0	147	0
	204	255	0	156	0
	205	255	0	165	0
	206	255	0	174	0
	207	255	0	183	0
	208	255	0	192	0
	209	255	0	201	0
	210	255	0	210	0
	211	255	0	219	0
	212	255	0	228	0
	213	255	0	237	0
	214	255	0	246	0
	215	255	0	255	0
	216	246	0	255	0
	217	237	0	255	0
	218	228	0	255	0
	219	219	0	255	0
	220	210	0	255	0
	221	201	0	255	0
	222	192	0	255	0
	223	183	0	255	0
	224	174	0	255	0
	225	165	0	255	0
	226	156	0	255	0
	227	147	0	255	0
	228	138	0	255	0

Robin 300X LEDWash - Virtual Colour Wheel

Scale*	Virtual Colour Wheel	Red	Green	Blue	White
	DMX	DMX	DMX	DMX	DMX
	229	129	0	255	0
	230	119	0	255	0
	231	110	0	255	0
	232	104	0	255	0
	233	98	0	255	0
	234	91	0	255	0
	235	84	0	255	0
	236	77	0	255	0
	237	70	0	255	0
	238	63	0	255	0
	239	56	0	255	0
	240	49	0	255	0
	241	42	0	255	0
	242	35	0	255	0
	243	28	0	255	0
	244	21	0	255	0
	245	14	0	255	0
	246	7	0	255	0
	247	0	0	255	0
	248-255 (Rainbow+ zone effects)	****	****	****	****
* Colour scale as an illustration only					