

ROBE

Divine 160 RGBW

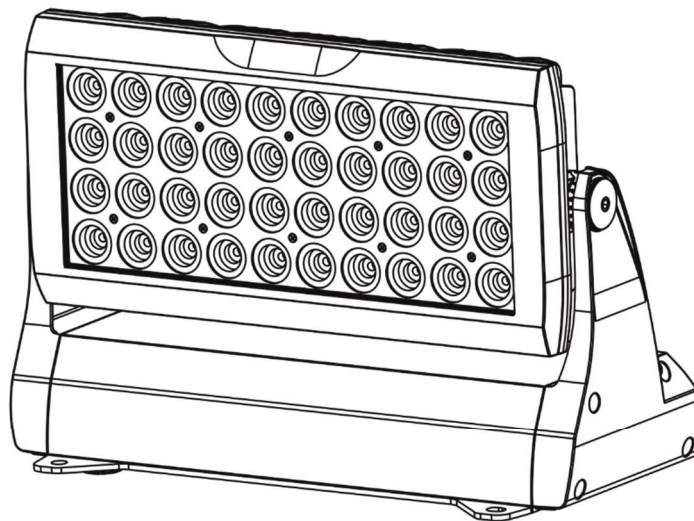

QR code for user manual



USER MANUAL

ROBE® Lighting s.r.o. • Czech republic • www.robe.cz

Version 1.7

Table of contents

1. Safety instructions	3
2. Fixture exterior view.....	5
3. Installation	5
3.1 Connection to the mains	5
3.2 Mounting the fixture	6
3.3 Top hat and half top hat installation	8
3.4 Barn door and Wire guard/anti-glare installation	9
3.5 DMX 512 connection	9
4. Divine 160 RGBW - DMX protocol	11
5. Control menu	14
5.1 Fixture Address	14
5.2 Fixture information.....	14
5.3 Personality	15
5.4 Manual mode.....	17
5.5 Test sequences.....	17
5.6 Stand-alone setting.....	17
5.7 Special functions.....	19
6. Technical specifications	20
7. Cleaning and maintenance	22
7.1 Replacing a fuse	22
7.2 Disposing of the product	23

**FOR YOUR OWN SAFETY, PLEASE READ THIS USER MANUAL CAREFULLY
BEFORE POWERING OR INSTALLING YOUR Divine 160 RGBW!
Save it for future reference.**

This device has left our premises in absolutely perfect condition. In order to maintain this condition and to ensure safe operation, it is absolutely necessary for the user to follow the safety instructions and warnings written in this manual.

The manufacturer will not accept liability for any resulting damages caused by the non-observance of this manual or any unauthorized modification to the device.

Unauthorized modification will void warranty.

This device is for professional use only. It is not for household use.

1. Safety instructions

DANGEROUS VOLTAGE CONSTITUTING A RISK OF ELECTRIC SHOCK IS PRESENT WITHIN THIS UNIT!

Make sure that the available voltage is not higher than stated on the rear side of the fixture. This fixture should be operated only from the type of power source indicated on the marking label. If you are not sure of the type of power supplied, consult your authorized distributor or local power company.

Always disconnect the fixture from AC power before servicing or cleaning internally.

Do not overload supply line as this can result in fire or electric shock.

Make sure the power/data cable is never crimped or damaged by sharp edges. Check the fixture and the power/data cable from time to time.

Do not install the unit near an open flame.

Refer servicing to qualified service personnel.

This fixture falls under protection class I. Therefore, this fixture has to be connected to a mains socket outlet with a protective earthing connection.

Do not connect this fixture to a dimmer pack.

Warning! Risk Group 2 LED product according to EN 62471.

LED light emission. Risk of eye injury.

Do not look straight at the fixture's LEDs during operation. The intense light beam may damage your eyes.

The light source contains blue LEDs.

Immunity of the equipment is designed for electromagnetic environments E1, E2, E3 according to the standard EN55103-2 ed.2 Electromagnetic compatibility. Product family standard for audio, video, audiovisual and entertainment lighting control apparatus for professional use. Part 2: Immunity.

The installation company should check levels of possible interferences above the tested levels E1,E2,E3 given by this standard (e.g. transmitters in surrounding area) before installing the equipment.

Emission of the equipment complies with the standard EN55032 Electromagnetic compatibility of multimedia equipment – Emission Requirements according to class B.

Divine 160 RGBW

Keep combustible materials at least 0.3 m away from the fixture.

If the fixture has been exposed to drastic temperature fluctuation (e.g. after transportation), do not switch it on immediately. The arising condensation of water might damage your device. Leave the device switched off until it has reached room temperature.

Avoid brute force when installing or operating the fixture.

When choosing the installation spot, please make sure that the fixture is not exposed to extreme heat or dust.

Avoid using the unit in locations subject to possible impacts.

Only operate the fixture after having checked that the housing is firmly closed and all screws are tightly fastened.

Do not block the front glass cover with any object when the fixture is under operation.

The fixture body must never be covered with cloth or other materials.

The fixture becomes very hot during operation. Allow the fixture to cool approximately 30 minutes prior to servicing or maintenance.

Operate the fixture only after having familiarized yourself with its functions. Do not permit operation by persons not qualified to operate the fixture. Most damages are the result of unprofessional operation!

Please consider that unauthorized modifications on the fixture are forbidden due to safety reasons!

Please use the original packaging if the fixture is to be transported.

If this device will be operated in any way different to the one described in this manual, the product may suffer damages and the warranty becomes void. Furthermore, any other operation may lead to dangers like short-circuit, burns, electric shock etc.

2. Fixture exterior view

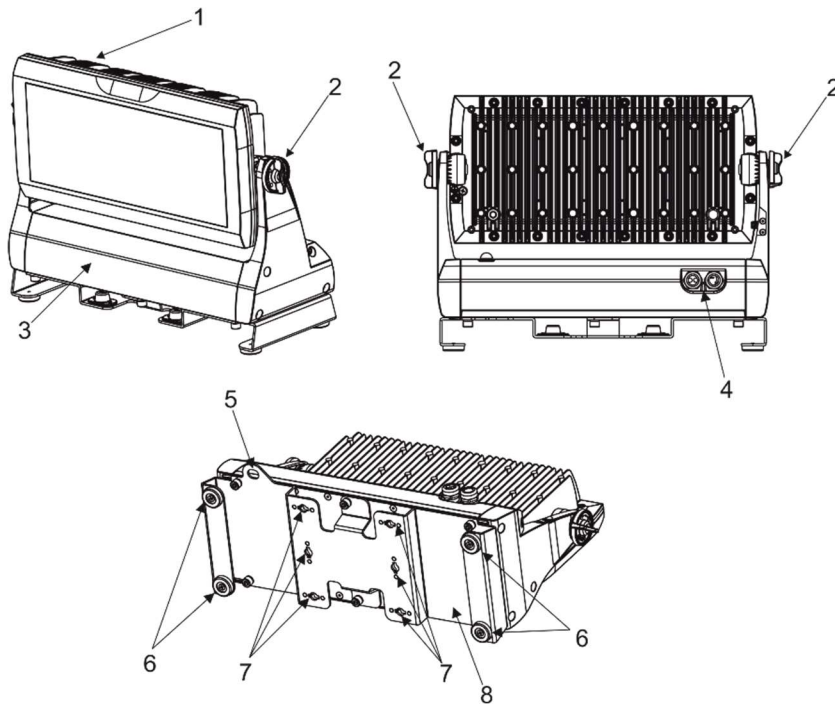

1. Head with LED array
2. Tilt lock
3. Base
4. Power and DMX connection
5. Attachment point for safety wire
6. Rubber feet
7. Openings for mounting brackets Omega CL assembled
8. Universal base adaptor for Strobe IP

3. Installation

3.1 Connection to the mains

***Fixture must be installed by a qualified electrician in accordance with all national and local electrical and construction codes and regulations.
This device falls under class one and must be grounded!***

The Divine 160 RGBW is equipped with auto-switching power supply that automatically adjusts to any 50-60Hz AC power source from 100-240V (CE) or 100-277 V (US). The fixture must be connected to a non-dimmable power source in order to avoid damage to its internal power supply and other electrical components. Connect the fixture to the mains by means of inbuilt power cord with the plug.

3.2 Mounting the fixture

Disconnect the fixture from mains prior to start any installation/assembly works.

The Divine 160 RGBW can be arranged in any position/orientation without altering its operation characteristics.

The LED module can be tilted to desired position by means of the tilt lock.

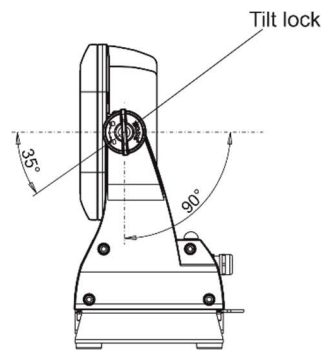

Universal base adaptor installation

Screw the universal base adaptor (8) to the base (3) of the fixture by means of six Allen head bolts M8x25 (12) with six spring washers .

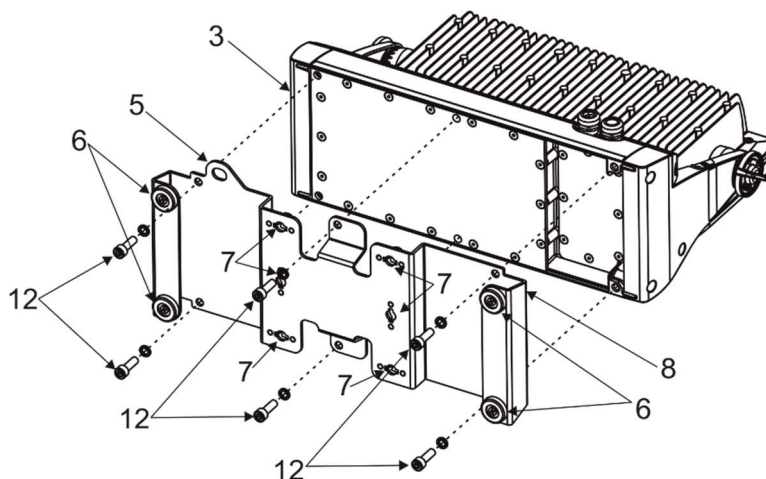

The Universal base adaptor of the fixture (8) is equipped with two pairs of rubber feet (6) for standing the fixture on the floor and three pairs of openings (7) for installation of the mounting adaptors Omega CL (9) which allow to rig the fixture to the truss.

For overhead installation, the fixture must be always secured with a safety wire.

A structure (truss) intended for installation of the fixture (s) must safely hold weight of the fixture(s) placed on it. The structure has to be certificated to the purpose.

The operator has to make sure that safety-relating and machine-technical installations are approved by an expert before taking into operation for the first time and after changes before taking into operation another time.

IMPORTANT! Overhead installation requires extensive experience including calculating working load limits, installation material being used, and periodic safety inspection of all installation material and fixtures. Fixtures may cause severe injuries when crashing down! If you have doubts concerning the safety of a possible installation, do not install the fixtures and consult installation with an expert.

CAUTION!
Use 2 mounting brackets Omega CL and appropriate clamps to rig the fixture on the truss.
Make sure that the device is fixed properly!
Ensure that the structure (truss) to which you are attaching the fixtures is secure.

The fixture must never be fixed swinging freely in the room.

For securing the fixture to the truss, install a safety wire which can hold at least 10 times the weight of the fixture. Use only the safety wire with a snap hook with screw lock gate.

Truss installation

1. Bolt clamp to the Omega adaptor CL (9) with M12 bolts and lock nuts through the hole in the adaptor Omega CL.
2. Fasten the Omega adaptors (adaptor) CL on the universal base adaptor (8) by means of the quick-lock fasteners (10) and tighten them fully clockwise.
3. Fasten the safety wire (11) in the attachment point (5) and around the truss.

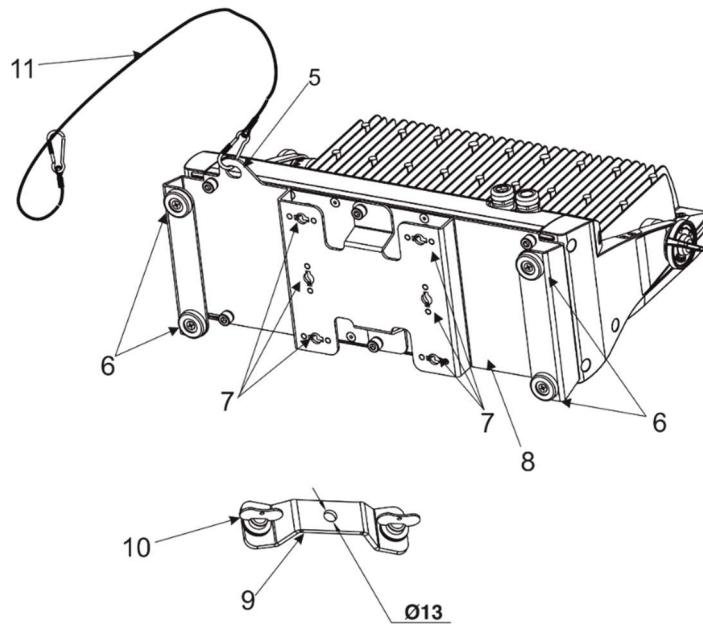

Possible positions of the adaptors Omega adaptors CL with clamps:

2-bracket installation

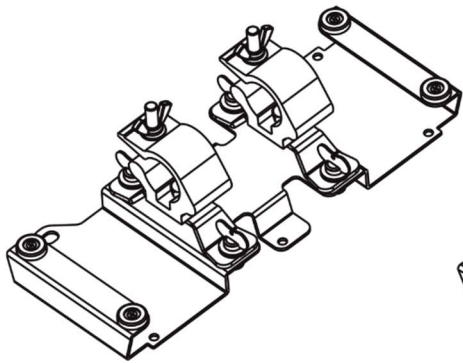

2-bracket installation

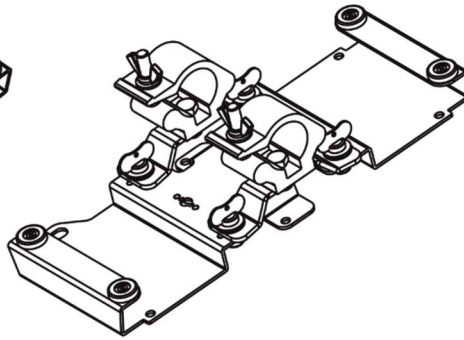

1-bracket installation

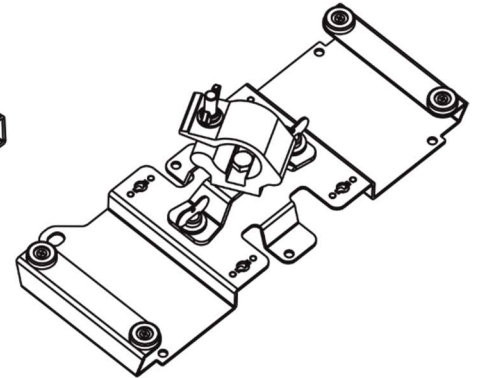

3.3 Top hat and half top hat installation

Half top hat

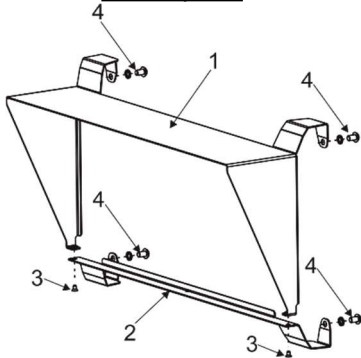

Top hat

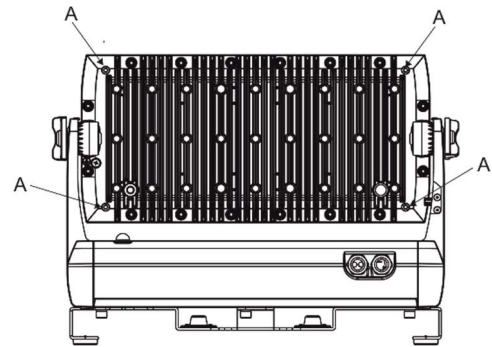
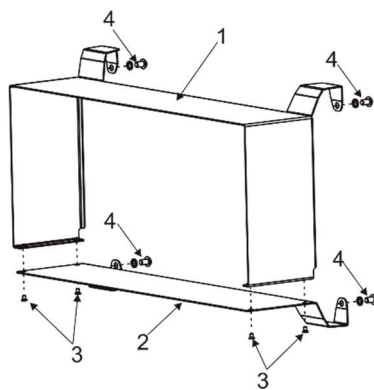

1. Unscrew screws M3x5 (3) to remove the bottom part (2) of the top hat (half top hat).
2. Place the upper part (1) of the top hat (half top hat) on the fixture head and secure it by means of two screws M5x8 (4) with spring washers to the two threaded holes (A) on the back side of the fixture head.
3. Place the bottom part (2) of the top hat (half top hat) on the bottom part of the fixture head and screw it back to the upper part (1) of the top hat (half top hat) by means of the screws M3x5 (3).
4. Secure the bottom part of the top hat (half top hat) to the fixture head by means of two screws M5x8 (4) with spring washers to the two threaded holes (A) on the back side of the fixture head.

3.4 Barn door and Wire guard/anti-glare installation

Barn door

Wire guard/anti-glare

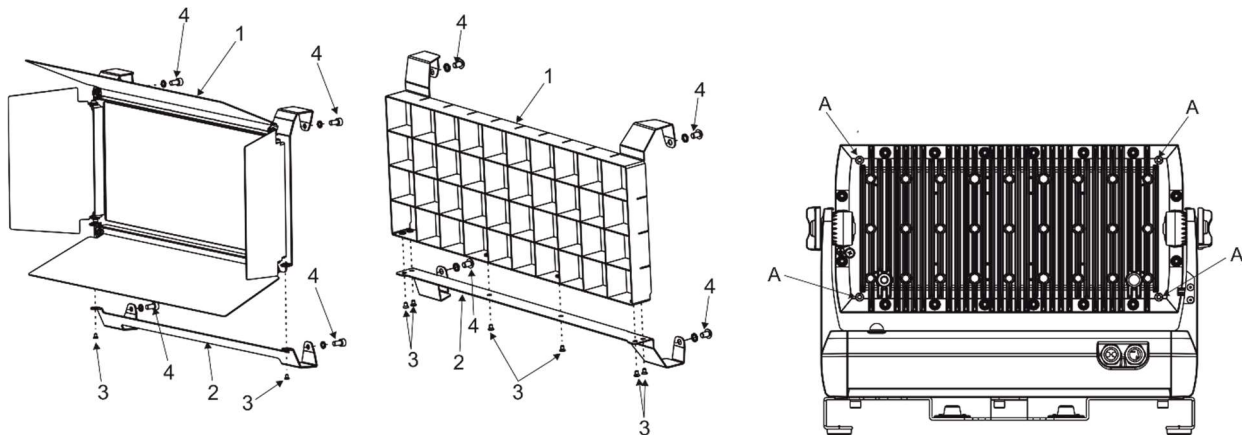

1. Unscrew screws M3x5 (3) to remove the bottom part (2) of the barn door (wire guard/anti-glare).
2. Place the upper part (1) of the barn door (wire guard/anti-glare) on the fixture head and secure it by means of two screws M5x10 (4) /M5x8 for wire guard/anti-glare/ with spring washers to the two threaded holes (A) on the back side of the fixture head.
3. Place the bottom part (2) of the barn door (wire guard/anti-glare) on the bottom part of the fixture head and screw it back to the upper part (1) of the barn door (wire guard/anti-glare) by means of the screws M3x5 (3).
4. Secure the bottom part of the barn door (wire guard/anti-glare) to the fixture head by means of two screws M5x10 (4) /M5x8 for wire guard/anti-glare/ with spring washers to the two threaded holes (A) on the back side of the fixture head.

3.5 DMX 512 connection

The fixture is equipped with 5-pin XLR connectors for DMX input/output. Only use a shielded twisted-pair cable designed for RS-485 and 5-pin XLR connectors in order to connect the controller with the fixture or one fixture with another.

Wiring of the XLR connectors:

XLR socket:



XLR plug:



- | | |
|---|-----------------|
| 1 | – Shield |
| 2 | - Signal (-) |
| 3 | - Signal (+) |
| 4 | – Not connected |
| 5 | – Not connected |

To build a DMX chain

1. Connect the DMX output of the controller directly with the DMX input of the first fixture in the DMX chain.
2. Connect the DMX output of the first fixture in the DMX chain with the DMX input of the next fixture.
3. Always connect the DMX output with the input of the next fixture until all fixtures are connected.
Do not overload the link. Max. 32 fixtures may be connected on a DMX link.

Divine 160 RGBW

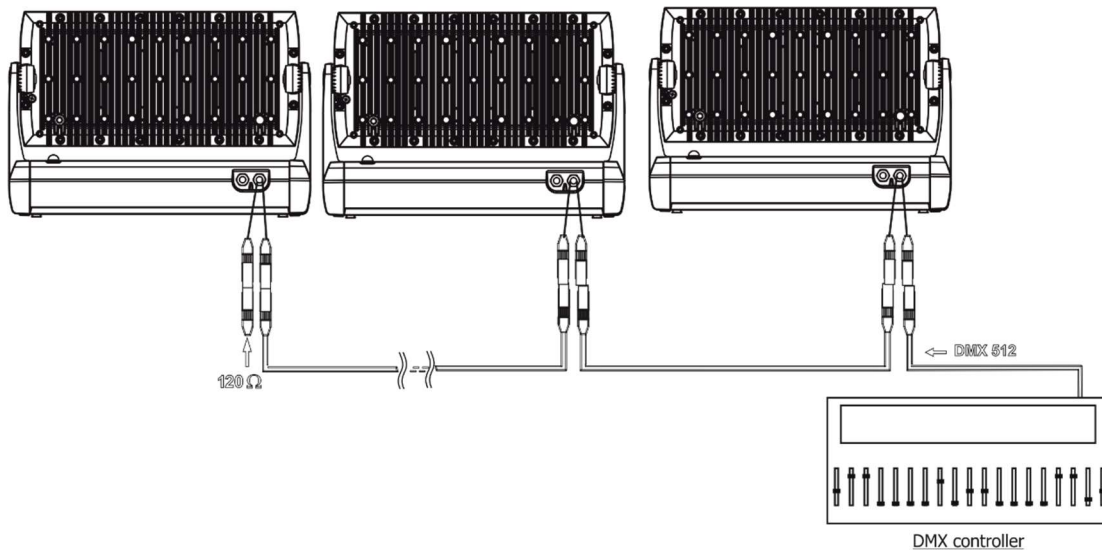

Caution: Terminate the link by installing a termination plug in the output of the last fixture. The termination plug is a male 5-pin XLR plug (IP 67 rating) with a 120 Ohm resistor soldered between Signal (-) and Signal (+).

Warning:

Fixture's XLR connectors are dust and water protected according to IP 67 by mating with related XLR cable connectors.

They cannot stay disconnected outdoor. DMX output connector (XLR female) at the last fixture in a DMX line has to be covered with the rubber cap before inserting a terminator. The rubber cap does not supply the terminator.

The XLR terminator (male) has to be dust and water protected.

If the fixture is to be outdoor without connecting to DMX line, always interconnect its DMX input with DMX output to keep declared IP rating of XLR connectors.

4. Divine 160 RGBW(RGBA) - DMX protocol

Version 1.4

Mode 1 Channel	Mode 2* Channel	Mode 3 Channel	Mode 4 Channel	Value	Function	Type of control
1	1	-	-	0-19	Special functions Reserved (0=default) To activate following functions , stop in DMX value for at least 3 sec. Corresponding menu items are temporarily overridden.	
				20-24	Display On	step
				25-29	Display Off	step
				30-39	RGBW colour mixing mode	step
				40-49	CMY colour mixing mode	step
				50-59	Colour calibration mode On	step
				60-69	Colour calibration mode Off	step
				70-89	Reserved	
				90-99	Dimmer curve: linear	step
				100-109	Dimmer curve: square law	step
				110-119	White count On	step
				120-129	White count Off	step
				130-255	Reserved	
2	-	1	1	0-255	Red – all zones Red LEDs saturation control (0-100%) (255=default)	proportional
3	-	2	2	0-255	Green – all zones Green LEDs saturation control (0-100%) (255=default)	proportional
4	-	3	3	0-255	Blue – all zones Blue LEDs saturation control (0-100%) (255=default)	proportional
5	-	4	4	0-255	White (Amber) – all zones LEDs saturation control (0-100%) (255=default)	proportional
-	2	-	-	0-255	Red - zone 1 Red LEDs saturation control (0-100%) (255=default)	proportional
-	3	-	-	0-255	Green - zone 1 Green LEDs saturation control (0-100%) (255=default)	proportional
-	4	-	-	0-255	Blue - zone 1 Blue LEDs saturation control (0-100%) (255=default)	proportional
-	5	-	-	0-255	White (Amber) - zone 1 LEDs saturation control (0-100%) (255=default)	proportional
-	6	-	-	0-255	Red zone 2 Red LEDs saturation control (0-100%) (255=default)	proportional
-	7	-	-	0-255	Green - zone 2 Green LEDs saturation control (0-100%) (255=default)	proportional
-	8	-	-	0-255	Blue - zone 2 Blue LEDs saturation control (0-100%) (255=default)	proportional
-	9	-	-	0-255	White (Amber) - zone 2 LEDs saturation control (0-100%) (255=default)	proportional
-	10	-	-	0-255	Red - zone 3 Red LEDs saturation control (0-100%) (255=default)	proportional
-	11	-	-	0-255	Green - zone 3 Green LEDs saturation control (0-100%) (255=default)	proportional
-	12	-	-	0-255	Blue - zone 3 Blue LEDs saturation control (0-100%) (255=default)	proportional

Divine 160 RGBW

-	13	-	-	0-255	White (Amber) - zone 3 LEDs saturation control (0-100%) (255=default)	proportional
-	14	-	-	0-255	Red - zone 4 Red LEDs saturation control (0-100%) (255=default)	proportional
-	15	-	-	0-255	Green - zone 4 Green LEDs saturation control (0-100%) (255=default)	proportional
-	16	-	-	0-255	Blue - zone 4 Blue LEDs saturation control (0-100%) (255=default)	proportional
-	17	-	-	0-255	White (Amber) - zone 4 LEDs saturation control (0-100%) (255=default)	proportional
6	18	-	-	0 1-255	CT0 - all zones No function (0=default) Colour temperature correction	step proportional
7	19	-	-	0 1-2 3 4-5 6 7-9 10-12 13-15 16 17-55 56 57 - 95 96 97 – 134 135 136 - 174 175 176 -214 215 216 - 246 247 248-251 252-255	Virtual colour wheel -all zones No function (0=default) White 2700 K White 2700 K (tungsten emulation)** White 3200 K White 3200 K (tungsten emulation)** White 4200 K White 5600 K White 8000 K Blue (Blue=full, Red+Green+White=0) Red=0, Green→up,Blue =full, White=0 Light Blue (Red=0, Green=full, Blue =full, white=0) Red=0, Green=full, Blue→down, White=0 Green (Red=0, Green=full, Blue =0, White=0) Red→up, Green=full, Blue=0, White=0 Yellow (Red=full, Green=full, Blue=0,White=0) Red=full, Green→down, Blue=0, White=0 Red (Red=full, Green=0, Blue=0, White=0) Red=full, Green=0, Blue→up, White=0 Magenta (Red=full, Green=0, Blue=full, White=0) Red→down, Green=0, Blue=full, White=0 Blue (Red=0, Green=0, Blue=full, White=0) Rainbow effect(with fade time) from min.->max. speed Rainbow effect(without fade time)from min.->max.speed	step step step step step step step step step step proportional step proportional step proportional step proportional step proportional step proportional proportional
8	20	-	-	0-31 32-63 64-95 96-127 128-143 144-159 160-191 192-223 224-255	Shutter/ Strobe – all zones Shutter closed Shutter open (32=default) Strobe-effect from slow to fast Shutter open Opening pulses in sequences slow--> fast Closing pulses in sequences fast --> slow Shutter open Random strobe-effects from slow to fast Shutter open	step step proportional step proportional proportional step proportional step
9	21	5	-	0 - 255	Dimmer coarse – all zones Dimmer intensity from 0% to 100% (0=default)	proportional
10	22	-	-	0 - 255	Dimmer fine - all zones Dimmer intensity from min.—>max. (0=default)	proportional

*Default mode

**Halogen lamp effect during dimming

Zone order:

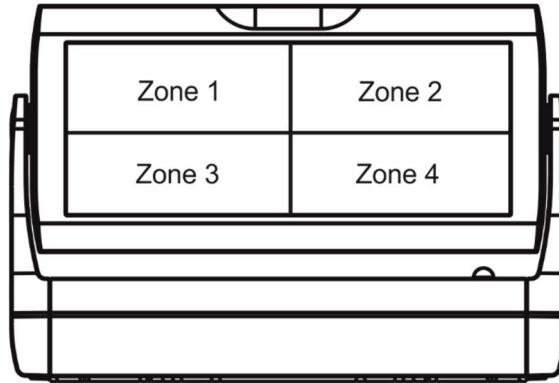

5. Control menu

The Divine 160 RGBW is equipped with a 4-segment LED display which allows you to set the fixture's behaviour according to your needs, obtain information on its operation, control all range of effects and program it in stand-alone mode.

The four control buttons have the following functions:

- ↖ - ESCAPE button-leaves menu without saving changes.
- ↵ - ENTER button- enters menu, confirms adjusted values and leaves menu.
- ▲ - UP and ▼ - DOWN buttons - move between menu items on the same level, sets values.

After switching the fixture on, display shows current DMX address.

A rectangular LED display showing the text 'A001' in a stylized, segmented font.

5.1 Fixture Address

A rectangular LED display showing the text 'A001' in a stylized, segmented font.

Use this menu to set the DMX address of the fixture.

dM.Ad. --- **DMX addressing.** Select this submenu to set a DMX start address.

To set a DMX address.

1. Use UP/DOWN buttons to find "A001" menu.
2. Press the ENTER button.
3. Use the UP/DOWN buttons to select desired start address.
4. Press the ENTER button to confirm the choice.

Note: After switching on, the Divine 160 RGBW will automatically detect whether DMX 512 data is received or not. If there is no data received at the DMX input, the display will start to flash the set address.

DM.Pr. --- **DMX preset.** Select this menu item to set a desired DMX mode.

5.2 Fixture information

A rectangular LED display showing the text 'Info' in a stylized, segmented font.

Use this menu to read useful information about the fixture status.

To display desired information.

1. Use the UP/DOWN buttons to find the "InFo" menu.
2. Press the ENTER button.
3. Use the UP/DOWN buttons to select the required menu item.
4. Press the ENTER button to confirm the choice.

Po.ti. --- **Power On Time.** Use the menu item to read the number of operation hours of the fixture.

totL - the function shows the total number of the operation hours since the Divine 160 RGBW has been fabricated.

rESEt - the function shows the number of the operation hours since the counter was last reset.

In order to reset this counter to 0, you have to press and hold the UP and DOWN buttons and at the same time press the ENTER button.

VErS. --- **Software Versions.** Select this function to read the software version of the fixture processors.

IC1.b. --- display processor 1

IC2.b. --- display processor 2

IC3.L. --- LED processor 3

IC4.L. --- LED processor 4

ViFi --- Wireless DMX module (if installed)

tEMP --- **Fixture Temperatures.** Select this menu to read the temperatures of the fixture:

bASE

Cur.t. --- the current temperature of the fixture base.

Hi.tE. --- the menu item shows the max. temperatures of the fixture base since the fixture has been fabricated.

rSet --- the menu item shows the maximum temperatures of the fixture base since the counter was last reset. In order to reset this counter to 0 you have to press and hold the UP and DOWN buttons and at the same time press the ENTER button.

LEdS

Cur.t. --- the current temperature of the fixture LEDs PCB.

Hi.tE. --- the menu item shows the max. temperatures of the LEDs PCB base since the fixture has been fabricated.

rSet --- the menu item shows the maximum temperatures of the LEDs PCB since the counter was last reset. In order to reset this counter to 0 you have to press and hold the UP and DOWN buttons and at the same time press the ENTER button.

The temperatures can be displayed in either °C or °F units - see option "tnP.u." in the menu "Pers".

DM.In.---**DMX values.** Select this function to read DMX values of each channel received by the fixture.

5.3 Personality



Use this menu to modify the Divine 160 RGBW operating behaviour.

DM.Pr. --- **DMX preset.** Select this menu item to set a desired DMX mode. Please refer to the chapter "DMX protocol" for detail description of each DMX mode.

dM.In. --- **DMX input.** Select this menu item to select desired DMX input:

UirE --- Wired DMX.

UirL --- Wireless DMX

UrLo --- Wireless DMX → wired DMX. The fixture receives wireless DMX signal and sends it to its DMX output connector. Next fixtures can be connected to this fixture by DMX cable (fixture works as a Wireless-DMX converter).

AnL.d. --- Analog dimmer. If this option is selected, the dimmer channel can be controlled via DC voltage (0-10V) connected between pins 1 (data ground) and 3 (Data +) of DMX input of the fixture (0-data ground, 10V-data +).

Procedure of setting:

1. Set fixture's channels at desired values (by means of menu item Init Positions "In.Po").
2. Disconnect DMX controller
3. Select option "AnL.d." from menu DMX input
4. Connect DC voltage to the DMX input of the fixture

F.tin. --- **Max. Fade time.** Select this menu item to set a desired max. fade time (0-25.4 sec.). This adjusted fade time influences fade of Red, Green, Blue, White and dimmer during DMX operation:

If time between two receiving DMX values is > than fade time set in the item "F.tin.", the entire adjusted fade time will be used.

If time between two receiving DMX values is < than fade time set in the item "F.tin.", the adjusted fade time will be reduced to fill entire time between the two receiving DMX values.

e.g "F.tin."=2sec. and fixture has received from DMX controller value Red=0 DMX, after 5 seconds will receive Red=255 DMX. It means, that red will go to full intensity during 2 seconds.

"F.tin."=8 sec. and fixture has received Red=0 DMX, after 5 seconds will receive Red=255 DMX. It means, that red will go to full intensity during 5 seconds. (Max. fade time is reduced from 8 sec. to 5 sec.).

DiSP. --- **Display adjusting.** This function allows you to change the display settings.

d.On --- this function allows you to keep the display on or to turn off automatically 2 minutes after pressing any button on the control panel.

d.Int. --- select this function to adjust the display intensity (6-min.,100-max.).

turn --- select this function to rotate menu 180 degrees from current orientation.

C.CL.n. --- **Colour calibration.** If the function is on, the white output (R+G+B+W=full, Whites 2700K,3200K, 4200K, 5600K and 8000K) from the fixture is more uniform.

C.MI.n. --- **Colour mixing mode.** This menu item allows to select desired colour mixing mode:

rGBU --- RGBW mode (RGBA mode)

CMY --- CMY mode (the white channel is not active in this mode)

diM.C. --- **Dimmer curve.** The menu item allows to select desired dimmer curve:

Lin. --- linear

SqL --- Square law

WhI.C. --- **White counting.** If this function is on, the white channel uses red, green and blue channels in proportional relation to ensure max. light output in a white colour (if white channel =full, also red, green and blue channels are full).

Vhl.t. --- **LED type.** The function allows you to set a correct type of colour LEDs.

L. Vhl. --- White LEDs. For fixture with Red, Green, Blue, White LEDs (RGBW type).

L. AMb. --- Amber LEDs. For fixture with Red, Green, Blue, Amber LEDs (RGBA type). If the option is selected, the menu item White counting (WhI.C.) is set off automatically, but you have a possibility to set it on again.

tnP.u. --- **Temperature unit.** Use this menu in order to display the fixture temperatures in desired units: °C or °F.

In.Po. --- **Init effect positions.** Use this function to set all effects to the desired positions to which they will move after switching the fixture on (if DMX is not receiving).

dF.SE. --- **Default Settings .**The menu item sets all fixture parameters to the default (factory) values.

5.4 Manual mode



Use this menu to control all channels via buttons of the control board.
Items in this menu depend on selected DMX mode.

To control fixture channels.

1. Use the UP/DOWN buttons to find “ Man.C “ menu.
2. Press the ENTER button.
3. Use the UP/DOWN buttons to select desired effect (channel).

List of control channels:

“Func” – a channel Special Functions

“rEd.1” – a red LEDs saturation coarse- zone 1

“GrE.1” – a green LEDs saturation coarse- zone 1

“bLU.1” – a blue LEDs saturation coarse- zone 1

“Vhl.1” – a white LEDs saturation coarse- zone 1

“rEd.2” – a red LEDs saturation coarse- zone 2

“GrE.2” – a green LEDs saturation coarse- zone 2

“bLU.2” – a blue LEDs saturation coarse- zone 2

“Vhl.2” – a white LEDs saturation coarse- zone 2

“rEd.3” – a red LEDs saturation coarse- zone 3

“GrE.3” – a green LEDs saturation coarse- zone 3

“bLU.3” – a blue LEDs saturation coarse- zone 3

“Vhl.3” – a white LEDs saturation coarse- zone 3

“rEd.4” – a red LEDs saturation coarse- zone 4

“GrE.4” – a green LEDs saturation coarse- zone 4

“bLU.4” – a blue LEDs saturation coarse- zone 4

“Vhl.4” – a white LEDs saturation coarse- zone 4

“Cto” – a colour temperature correction

“Vir.C.” – a virtual colour wheel

“Stro.” - a strobe/shutter

“dinr” - a coarse dimmer

“din.F” a fine dimmer

4. Press the ENTER button and use the UP/DOWN buttons to set value , press the ENTER button to confirm it.

5.5 Test sequences



Use this menu to run demo-test sequences without an external controller, which will show you some possibilities of using the Divine 160 RGBW.

5.6 Stand-alone setting

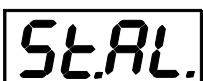

The fixtures on a data link are not connected to the controller but can execute pre-set programs which can be different for every fixture. “Stand-alone operation” can be applied to the single fixture or to multiple fixtures operating synchronously.

Auto. --- Automatic playback. This function allows you to select the program which will be played after switching the fixture on. Selected program will be played continuously in a loop.

1. Use the UP/DOWN buttons to select test program ("tEst"), user program ("u.PrG") or disable this function (OFF).
2. Press the ENTER button to confirm the choice.

PLAY --- Playing program. Entering this menu provides a complete overview of all programs offered, from which the selected program can run.

1. Use the UP/DOWN buttons to select desired program.
2. Press the ENTER button. The selected program runs in a loop.

Edit --- Editing a program. The fixture offers a freely editable program up to 40 steps. Every program step includes a step time-the total time occupied by the step in the program and a fade time- during which effects move to new positions.

1. Use the UP/DOWN buttons to select a desired program step ("St.01" - "St.40") and press ENTER button.
2. Use the UP/DOWN buttons to select a channel you want to edit and press the ENTER button.

List of editable items:

"P.End" - a total number of the program steps (value 1-40). This value should be set before start of programming (e.g. if you want to create a program with 10 steps, set P.End=10).

"Func" - a channel Special Functions

"rEd.1" - a red LEDs saturation coarse- zone 1

"GrE.1" - a green LEDs saturation coarse- zone 1

"bLU.1" - a blue LEDs saturation coarse- zone 1

"Vhl.1" - a white LEDs saturation coarse- zone 1

"rEd.2" - a red LEDs saturation coarse- zone 2

"GrE.2" - a green LEDs saturation coarse- zone 2

"bLU.2" - a blue LEDs saturation coarse- zone 2

"Vhl.2" - a white LEDs saturation coarse- zone 2

"rEd.3" - a red LEDs saturation coarse- zone 3

"GrE.3" - a green LEDs saturation coarse- zone 3

"bLU.3" - a blue LEDs saturation coarse- zone 3

"Vhl.3" - a white LEDs saturation coarse- zone 3

"rEd.4" - a red LEDs saturation coarse- zone 4

"GrE.4" - a green LEDs saturation coarse- zone 4

"bLU.4" - a blue LEDs saturation coarse- zone 4

"Vhl.4" - a white LEDs saturation coarse- zone 4

"Cto" - a colour temperature correction

"Vir.C." - a virtual colour wheel

"Stro." - a strobe/shutter

"dinr" - a coarse dimmer

"din.F" a fine dimmer

"F.tin" a fade time

"S.tin" a step time

"COPY" - this item duplicates the current prog. step to the next prog. step.

Note: Items in this menu depend on selected DMX mode.

3. Use the UP/DOWN buttons to set a DMX value of the channel and then press the ENTER button.
4. Use the UP/DOWN buttons to select next channel and press the ENTER button.
5. After having set all channels in the current program step, press the ESCAPE button to go one menu level back and select another program step.

5.7 Special functions



rdM.L --- **Code.** This menu item shows the first part of the RDM identification code.

rdM.H --- **Code.** This menu item shows the second part of the RDM identification code.

WiFi --- **Wireless DMX.** The menu serves for reading of the wireless operation status (only for Wireless DMX version).

50 --- **Wireless DMX signal intensity.** The menu item shows level of received signal in %. If the fixture is not linked to the transmitter, "niSS" is displayed.

UnLI --- **Wireless DMX unlink.** The item serves for unlinking the fixture from transmitter.

Adj --- **Effect Adjustment.** The menu allows calibration of white colours.

dMH --- **DMX Values.** The menu item allows to set desired colour before calibrating of white colours.

C.CAL --- **Colour calibration.** Calibration of white colours.

LOA.C. – Loading a default (factory) calibration.

uPd.M. --- **Updating mode.** The menu item allows you to update software in the fixture via either serial or USB port of PC.

The following are required in order to update software:

- PC running Windows or Linux or macOS
 - DSU file
 - Flash cable RS232/DMX P/N13050624 (if you want to use a serial port of PC)
 - Robe Universal Interface or Robe Universal interface WTX (if you want to use an USB port of PC)
- DMX address, user program and all items in the menu "PerS" will be set to their default (factory) values.

To update software in the fixture:

1. DSU file is available from Robe web site at <https://www.robe.cz/architectural/download/#software-updates>
File with extension zip is intended for Windows (used and tested from XP to W10 on 32/64bit systems).
File with extension tbz is intended for Linux (used and tested on Debian and Ubuntu 32/64bit).
File with extension dmg is intended for macOS (used and tested on OSX up to Sierra) XQuartz required, install it from <https://www.xquartz.org/>
Save the download file to a folder on your computer.
In case that you use windows, extract files in the zip file (e.g. DSU_Divine160RGBW_19013038.zip)
2. Disconnect the fixture from DMX controller.
3. If you use the flash cable RS232/DMX, connect a serial port of your computer with DMX input of the fixture by means of the cable.
If you use the Robe Universal Interface, connect a USB port of your computer with the Robe Universal Interface by means of the USB cable and DMX input of the fixture with the DMX output of the Robe Universal Interface via a DMX cable.
4. Switch the fixture to the update mode (SPEC --> uPd.M. -->yES).
Note: If you do not want to continue in the software update, you have to switch off and on the fixture to escape from the updating mode.
We recommend to cancel all running programs on your computer before starting the software update.
5. Double-click the software uploader file (e.g. DSU_Divine160RGBW_19013038.exe) in the extracted files. The Software Uploader program will start running.
6. Select correct "COM " number if you use a Flash cable RS232/DMX or select "Robe Universal Interface " if you use the Robe Universal Interface/Robe Universal Interface WTX and then click on the "Connect" button.
7. If the connection is OK, click the "Start Uploading" button to start software uploading. It will take several minutes to perform software update.

If the option "Incremental Update" is not checked, all processors will be updated (including processors with the same software version).

If you wish to update only processors with not topical versions of software, check the "Incremental Update box".

Avoid interrupting the process. Update status is being displayed in the "Info Box" window.

When the update is finished, the line with the text "Fixture is successfully updated" will appear in this window.

In case upload process is interrupted (e.g. power loss), the fixture stays in "Updating mode" and you will have to repeat the software update again.

Another way, how to update software in the fixtures (especially large installation of fixtures) is to use the ROBE Uploader. It is a software for automatized software update of ROBE fixtures.

For more information please see <https://www.robe.cz/robe-uploader/>.

6. Technical specifications

Power supply

- Electronic auto-ranging
- Input voltage (EU): 100 - 240V AC, 50-60 Hz
- Input voltage (US): 100 - 277V AC, 50-60 Hz
- Max. power consumption: 440W
- Inrush current: 30A (at 230V), 20A (at 115V)

Optic & Effects

- Light source: 40 x multi-chip LEDs
- Beam angle (RGBW variant): 16°, 24°, 41°
- Beam angle (CW, WW, SW variant): 13°, 24°, 39°
- 4 LED zones
- RGBW colour mixing
- Built-in colour macros
- Adjustable strobe sequences
- Typical Lumen maintenance: 70% @ 60.000 hours

Control

- Setting & Addressing: 4-segment LED display & 4 control buttons
- Control: USITT DMX 512 (RDM support)
- DMX protocol modes: 2 (10,22 control channels)
- Operations modes: DMX, Stand-alone
- Manual control of all effects via control panel
- One editable program, up to 40 steps

Wireless DMX/RDM module (only for wireless DMX version of the Divine 160 RGBW)

- Compliance with USITT DMX-512 (1986 & 1990) and 512-A
- Full DMX fidelity and frame integrity
- Auto sensing of DMX frame rate and frame size
- <5ms DMX latency
- Operational frequency range of 2402-2480 MHz
- Producer: LumenRadio

Strobe

Divine 160 RGBW

- Strobe effect with variable speed (max. 20 flashes per second)
- Pre-programmed random strobe pulse-effects

Dimmer

- Smooth 16-bit dimming from 0 - 100 %

Connection

- 2x Outdoor DMX cable CA-0611 + 2x 5-pin XLR (male, female IP 67)
- 1x power cable with plug

Mounting

- Via Universal base adaptor for Strobe IP

Protection factor

- **EU:** IP 67 (except power plug)
- **US:** Suitable for wet location (except power plug)

Impact rating

- IK10

Temperatures

- Operating Ambient Temperature: -20°C / +40°C (-4°F / +104°F)
- Operating Temperature: +75°C @ Ambient +40°C (+167°F @ Ambient +104°F)

Minimum distance

Min. distance from flammable material: 0.3 m

Total heat dissipation

- 1500 BTU/h (calculated)

Weight

- 14.5 kg

Divine 160 RGBW

Dimensions mm[inch]

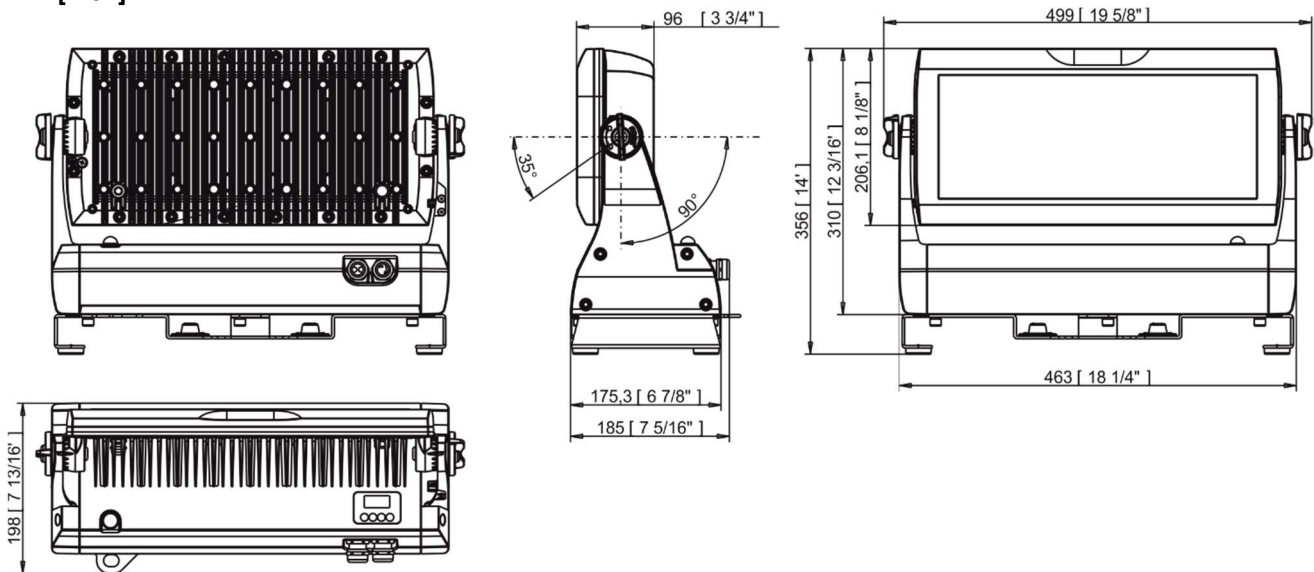

Included items

- 1 x Divine 160 RGBW
- 1 x Universal base adaptor for Strobe IP (P/N 10980379)
- 1 x User manual

Optional accessories

- Top Hat Divine 160 black (P/N 10980382)
- Half Top Hat Divine 160 black (P/N 10980383)
- Wire Guard/Anti-Glare Divine 160 black (P/N 10980384)
- Barn Door Module for Divine 160 black (P/N10980380)
- Set of Rubber Feet black (P/N 10980370)
- Omega adaptor CL-regular 2 pcs in box (P/N 10980033)
- Doughty Trigger Clamp (P/N (17030386)
- Safety wire 35kg (P/N 99011963)

7. Cleaning and maintenance

DANGER !

Disconnect from the mains before starting any cleaning or maintenance work

Rinse off loose dirt with low pressure water spray. Wash the housing with a soft brush or sponge and a mild, non-abrasive washing detergent. Rinse it.

Maintenance and service operations are only to be carried out by a qualified person. Should you need any spare parts, please use Robe OEM parts.

7.1 Replacing a fuse

This replacement has to be realized by a qualified person or Robe service worker only.

7.2 Disposing of the product

To preserve the environment please dispose or recycle this product at the end of its life according to the local regulations and codes.

Specifications are subject to change without notice

May 31, 2022

Copyright © 2017-2022 Robe Lighting - All rights reserved

Made in CZECH REPUBLIC by ROBE LIGHTING s.r.o. Palackeho 416/20 CZ 75701 Valasske Mezirici