



**Poly G7500, Poly Studio X70,  
Poly Studio X50, Poly Studio  
X30, and Poly Studio E70**  
Room Preparation Guide

December 2022 | 3725-85910-006B

# Contents

Before You Begin .....	3
Audience, Purpose, and Required Skills .....	3
Installation Prerequisites .....	3
Related Poly and Partner Resources .....	3
Privacy Policy .....	3
General Room Recommendations .....	4
Walls .....	4
Windows .....	4
Ceiling .....	5
Floors .....	5
Heating, Ventilation, and Air Conditioning .....	5
Vibration .....	6
Room Color .....	6
Lighting Recommendations .....	6
Acoustic Recommendations .....	7
Network Readiness .....	8
Room Layout Recommendations .....	9
Recommended Room Dimensions .....	9
Room Layout Examples .....	9
Codec Placement .....	12
System Characteristics and Cable Lengths .....	12
G7500 .....	12
Studio E70 .....	13
Studio X70 .....	13
Studio X50 .....	14
Studio X30 .....	14
LAN Ports and Power Outlet Placement .....	15
Camera Placement .....	15
Camera Placement on Monitors .....	16
Field of View .....	16
Camera Auto-Framing .....	18
Camera Framing Examples .....	19
Microphone Placement .....	20
Audio Pickup Ranges .....	20
Example Microphone Placement Layouts .....	21
Maximum Volume and Full Duplex .....	22
Display Options .....	22
Poly Acoustic Fence and Poly Acoustic Fence with Beam Shaping Technology .....	23
Poly Acoustic Fence with G7500 Systems .....	23
Poly Acoustic Fence Ceiling Microphone Array .....	23
Supported Poly Acoustic Fence Configurations .....	23
Example Layouts for Poly Acoustic Fence .....	24
Configure Poly Acoustic Fence .....	26
Poly Acoustic Fence with Beam Shaping with Studio X Family Systems .....	27
Configure Poly Acoustic Fence with Beam Shaping .....	28
Example Layouts for Poly Acoustic Fence with Beam Shaping .....	28

# Before You Begin

Use this guide to plan and prepare your video conferencing room before installing a Poly G7500 or Poly Studio X Family system (Poly Studio X70, Poly Studio X50, Poly Studio X30) or a Poly Studio E70 camera.

## Audience, Purpose, and Required Skills

This document is intended for Poly partners, resellers, and installers who want guidance in preparing conference rooms for system installation.

You must be familiar with the following concepts before beginning:

- Current telecommunications practices, protocols, and principles.
- Telecommunication basics, video conferencing, and voice or data equipment.
- Knowledge and experience with audio/video (A/V) cable installation and management.

## Installation Prerequisites

Before installers arrive onsite, install the following items:

- Cabling inside floors, walls, and ceilings.
- Ceiling- or wall-mounted brackets used to support Poly and non-Poly equipment. This includes displays, projectors, microphones, speakers, projection screens, and cameras.

**Note:** If you're using installers, they can install the system, test it, and show the system working in a temporary state. You can then unplug and route cables as you wish.

## Related Poly and Partner Resources

See the following sites for information related to this product.

- [Poly Support](#) is the entry point to online product, service, and solution support information. Find product-specific information such as Knowledge Base articles, Support Videos, Guide & Manuals, and Software Releases on the Products page, download software for desktop and mobile platforms from Downloads & Apps, and access additional services.
- The [Poly Documentation Library](#) provides support documentation for active products, services, and solutions. The documentation displays in responsive HTML5 format so that you can easily access and view installation, configuration, or administration content from any online device.
- The [Poly Community](#) provides access to the latest developer and support information. Create an account to access Poly support personnel and participate in developer and support forums. You can find the latest information on hardware, software, and partner solutions topics, share ideas, and solve problems with your colleagues.
- The [Poly Partner Network](#) is a program where resellers, distributors, solutions providers, and unified communications providers deliver high-value business solutions that meet critical customer needs, making it easy for you to communicate face-to-face using the applications and devices you use every day.
- [Poly Services](#) help your business succeed and get the most out of your investment through the benefits of collaboration. Enhance collaboration for your employees by accessing Poly service solutions, including Support Services, Managed Services, Professional Services, and Training Services.
- With [Poly+](#) you get exclusive premium features, insights and management tools necessary to keep employee devices up, running, and ready for action.
- [Poly Lens](#) enables better collaboration for every user in every workspace. It is designed to spotlight the health and efficiency of your spaces and devices by providing actionable insights and simplifying device management.

## Privacy Policy

Poly products and services process customer data in a manner consistent with the [Poly Privacy Policy](#). Please direct comments or questions to [privacy@poly.com](mailto:privacy@poly.com).

# General Room Recommendations

The following sections provide general guidelines to improve room acoustics and create a more enjoyable collaborative experience with your Poly video conferencing system.

Following the recommendations significantly enhances the effectiveness of your conference room for meetings and presentations.

Some sections are reprinted from the *Basics of Audio and Visual Systems Design: Revised Edition*, Chapter 12, "Videoconferencing" written by Scott Sharer, CTS, and Jim Smith, CVE, CTS, copyright 2003, with permission of the Audiovisual and Integrated Experience Association® <https://www.avixa.org>.

**Note:** For detailed conference room setup for offices, and configuration options available on different platforms, visit Poly's online room setup and configuration tool "Poly Spaces": <https://spaces.poly.com>.

## Walls

The construction of the walls affects the quality of your video conferencing experience. Consider the following recommendations.

**Note:** Wall materials are available from a variety of manufacturers. Be sure to consult your local building codes for additional requirements for your region.

### Wall Recommendations

Recommendation	Explanation
Make sure the conference room walls are built from slab to slab.	This means there are no gaps from the concrete of one floor to the concrete of the next floor.
Use resilient, gypsum board mountings to close any gaps.	The required thickness of the gypsum board is 15.9 mm (5/8 in.) or more. For example, one layer of 15.9 mm (5/8 in.) and one layer of 12 mm (1/2 in.) bonded together is ideal for the inside of the room, with a 12 mm (1/2 in.) thick layer (or as required by local building codes) for the outside walls.
Use an appropriate thickness for the inside and outer walls.	There must always be a difference in thickness between the material used on the inside versus outer walls. The difference in thickness subdues mechanical coupling (vibration) between the two layers. A good overall wall thickness is 152.4 mm (6 in.). Poly recommends that you use offset stud construction. This is typically a 152.44 mm (6 in.) header and footer with 88.9 mm (3.5 in.) verticals attached in an alternating pattern, with one toward the outside of the footer and the next toward the inside.
Place fiberglass dense batting or mineral rock wool, 101.6 mm to 152.4 mm (4 in. to 6 in.) thick (the equivalent of R-11 to R-13), in the wall space.	The thickness of the batting isn't critical, but you must loosely place it in the wall space, not compacted to fit. The resulting wall has excellent acoustic isolation from the outside world. You can achieve more significant acoustic isolation by placing an additional barrier layer within the wall space. Typically, this barrier is made of a dense polymer material, about 3.175 mm (1/8 in.) thick, and the sound-dampening improvement through the wall is roughly a factor of 10.

## Windows

Because natural light and sound from windows vary, windows can interfere with the acoustics of a room, alter the way a camera renders colors and brightness, and affect the quality of the video conferencing experience in general. Windows not only transmit room sound, but they also let unwanted outside noise intrude on the conference space.

Consider the following recommendations.

### Windows Recommendations

Recommendation	Explanation
Cover any outdoor-facing windows with curtains.	If this isn't possible, consider removing the windows entirely.
Use window treatments that match the interior look and feel of the space and provide a high level of sound and light block.	A heavyweight drape of 268 g (4 oz) or more, of heavy fullness, with no less than 15 cm (6 in.) fullness or no less than 20 cm (8 in.) centers per fold is best.
Avoid using sheer draperies or standard vertical or horizontal blinds.	These window treatments don't efficiently block sound and light.

### Ceiling

Adding high-quality acoustic tiles optimizes the room's sound quality. If you choose to add acoustic tiles to enhance the rooms acoustics, consider the following recommendations.

**Note:** Consult your local building codes for materials allowed in the various aspects of room acoustic modifications.

### Ceiling Recommendations

Recommendation	Explanation
Install 2.5 cm (1 in.) thick compressed dense core fiberglass tiles to the room's ceiling.	These types of ceiling tiles work well with indirect lighting.
Blanket the ceiling tiles completely from the plenum (air space) area.	This prevents sound from bouncing around uncontrolled and traveling from room to room throughout the plenum. Use a minimum of 15 cm (6 in) thick unfaced dense fiberglass batting or mineral rock wool (the equivalent of R-15 to R-19) for the blanket.
Add a barrier layer between the ceiling tiles and the blanket.	This improves acoustic performance and minimizes extraneous noise from leaving or entering the room through the ceiling. If the weight of the blanket and barrier layer prevents easy access to and from the ceiling, suspend the blanket and barrier layer above the ceiling tiles instead of resting on them.

### Floors

Conference room floors are typically out of the camera view but require planning because the material you choose might impact the quality of acoustics in the room. A room with carpet, for example, absorbs sound more effectively than one with hard flooring material.

In addition to choosing floor covering material that best suits aesthetic considerations, consider the following recommendations:

- Choose flooring that is neutral in color.
- Use carpeting with an underlying pad.
- If you must use hard flooring material, note that extra consideration for the acoustic absorptive qualities of the ceiling becomes significantly more important.

### Heating, Ventilation, and Air Conditioning

The location of heating, ventilation, and air conditioning (HVAC) equipment within the ceiling of a conference room often renders the room unusable for video or audio-only conferences due to the noise associated with the equipment. Consider using a room where all HVAC equipment is located outside the meeting room.

If the meeting room must include HVAC equipment, consider including the following adaptations to provide the best meeting experience.

### Heating, Ventilation, and Air Conditioning Recommendations

Recommendation	Explanation
Include at least a 1.2 m (4 ft) separation between any HVAC equipment (particularly the air conditioning equipment) and the microphones.	Your room may require a greater distance, depending on the noise level of your HVAC equipment.
Replace the air vents with low-velocity diffusers.	This eliminates wind noise when the HVAC system is running.
Install HVAC ducts and diffusers that are oversized for the general application in the space.	Insulated flexible ducts and noise dampening diffusers with a minimum diameter of 0.61 m (2 ft) generally work best.
Install all ducts with gradual bends and curves rather than rigid 90-degree corners.	This minimizes thunder-like sounds when the HVAC system turns on and air pushes through the ductwork into the room.

### Vibration

Excessive room or wall vibration can negatively affect video performance due to camera movement that may be noticeable by far-end participants.

Many factors cause room or wall vibration, such as HVAC equipment mounted nearby, heavy machinery in use nearby, high-rise structural vibrations, building sway or movement, and even trains or subways passing nearby or underneath the building.

Consider the following tips for addressing vibration issues:

- Consult the building manager, an architect, or a contractor to determine the optimal placement for your Poly system if building vibrations are a concern.
- If there are known vibration issues, please contact your Poly sales representative or speak to your Poly project manager before system installation.

### Room Color

The color of the walls in the meeting room can significantly impact the far end's experience and alter the far end's perception of the video quality.

Consider the following color usage recommendations:

- Avoid saturated color walls such as pure red or pure yellow as they can affect the auto white balance of the cameras.
- Walls in light gray with hints of blue work best. For rooms with bright lighting, slightly darker colors work as well.
- If your room includes acoustic panels, make sure that panels within the camera view are colored silver, light gray, quartz, or champagne.

### Lighting Recommendations

When preparing to install a Poly VideoOS system, you must provide optimal lighting that strengthens the capability of the video camera to effectively manage differences in brightness.

The brightness of the lighting in a video conference room plays an important role in determining the quality of video for the far end. Well-lit rooms, scenes, and images have a better chance of accurate detection, which ultimately results in better framing experiences.

Consider the following lighting recommendations when providing the proper lighting for a Poly VideoOS system.

## Lighting Recommendations

Recommendation	Explanation
Use indirect fluorescent or LED lighting for 80% to 85% of the room's lighting and use evenly distributed direct lighting for the remaining 15% to 20%.	Indirect lighting works by using the upper walls and ceiling as reflectors to diffuse the light. It also helps minimize shadows on participants' faces and makes the room more comfortable for viewing the far end on the monitor. Direct light on the walls creates backlight separation between foreground and background objects or surfaces.
Use a consistent color temperature.	Varying colors of lighting in a camera's field of view can interfere with its automatic compensations. Poly recommends a color temperature of 3,000 K to 3,800 K. If there's a significant quantity of outdoor light entering the room, use a light temperature that is more than 5,500 K. Avoid using 2800 K light sources.
Use no less than 30 fc (323 lux) and ideally as much as 55 fc (592 lux) of light on participants' faces in view of the camera.	Bright light increases the range of in-focus objects. Participants at the far end see more people in sharp focus, and the codec has an easier time encoding the image. Make sure that lighting is completely even across the field of view and illuminates conference participants' faces without being in the camera's field of view.
Avoid standard direct fluorescent lights or spotlights.	This type of lighting can interfere with the clarity of video sent to the far end and cast significant shadows on the participants.
Avoid dark environments or situations where bright light is thrown on the camera lens.	Too much backlight causes dark image generation and can make the faces of those on camera blend in with the room background.

## Acoustic Recommendations

The acoustic and noise levels in a room can greatly impact the audio quality during a meeting. Sounds from adjacent rooms (such as meeting rooms, offices, kitchens, reception areas, restrooms, or data centers) may interfere with the audio during conferences.

Make sure the Noise Criteria (NC) rating for the room is better than NC30 with less than a 43dBA SPL ambient noise level. If the room doesn't meet the NC rating, consider another room, or consult with an architect to help you determine ways to reduce noise within the room. The quieter the room, the easier it is to hear others in the same room, hear the far end, and for the far end to hear you.

To provide the best conferencing experience, consider the following acoustic treatment tips to maximize the performance of the integrated microphones:

- Use acoustic treatment on at least two adjoining walls, including the walls with mounted monitors.
- Use acoustic treatment on any walls adjoining hallways or office spaces.
- Cover at least 50% of the wall with acoustic panels that are 2.5 cm (1 in.) thick compressed, dense-core fiberglass (fabric-covered or equivalent) with an average sound absorption index of 0.9.
- To reduce noise disturbance to surrounding areas, laminate an additional barrier layer to the dense-core material, such as 1 cm (3/8 in) thick fiber compression board. Place the barrier layer against the existing wall material then place the acoustic absorption panels on the interior-room side of that. The barrier panels must have a sound absorption index of 0.9 and an additional specification of a sound transmission coefficient (STC) of 20. A high-quality conference room wall usually has an STC of 60 or more.

**Note:** A high-quality conference room wall usually has an STC of 60 or more.

You can also minimize acoustic and noise levels near a conference room by enabling and configuring Poly Acoustic Fence and Poly Acoustic Fence with Beam Shaping Technology. For more information, see [Poly Acoustic Fence and Poly Acoustic Fence with Beam Shaping Technology](#).

## Network Readiness

Network readiness is an important component of preparing a room for high-quality video communication. Make sure your network bandwidth and security measures meet the minimum requirements of your applicable platforms and supports your anticipated network traffic. For more information, see the network and firewall requirements outlined in the following documentation (as applicable):

- [Poly Video Mode Administrator Guide](#)
- [Prepare your organization's network for Microsoft Teams](#)
- [System Requirements for Zoom Rooms](#)



# Room Layout Recommendations

Following the requirements, recommendations, and considerations in this section provides the best meeting experience for meeting participants.

Consider the following information before the installation visit for your Poly G7500 or Studio X Family video conferencing system:

- Recommended room dimensions
- Codec placement
- System characteristics and cable lengths
- LAN ports and power outlet placement
- Camera placement
- Microphone placement
- Display options

## Recommended Room Dimensions

Poly recommends using the appropriate video conferencing system based on your conferencing room size. Using a video conferencing system in a room that is too large, for example, may lead to cut off audio or a decrease in video quality.

The following table lists recommended room dimensions.

**Note:** Camera distance refers to the recommended maximum distance of the room participant that is furthest from the camera. See [Camera Placement](#) for more information, including example camera framing diagrams.

### Room Dimensions

Room Size	Recommended Dimensions	Recommended Poly System	Camera Distance
Extra Large	>6 m (19.7 ft) x 10 m (32.8ft)	G7500 with connected Poly EagleEye IV or Poly EagleEye IV USB Camera	> 6.1 m (20 ft)
Large	6 m (19.7 ft) x 10 m (32.8 ft)	G7500 system with connected Studio E70 camera or Studio X70 system with built-in camera	6.1 m (20 ft)
Medium	4.5 m (14.8 ft) x 6 m (19.7 ft)	Studio X70 or Studio X50 system with built-in camera	4.6 m (15 ft)
Small	3 m (9.8 ft) x 4.5 m (14.8 ft)	Studio X50 system with built-in camera	3.7 m (12 ft)
Huddle	3 m (9.8 ft) x 3 m (9.8 ft)	Studio X30 system with built-in camera	2.4 m (8 ft)

## Room Layout Examples

The following diagrams are example layouts for setting up a conference room with Poly G7500 and Studio X Family systems.

### G7500

G7500 systems with a Studio E70 camera are ideal for large-sized conference rooms.

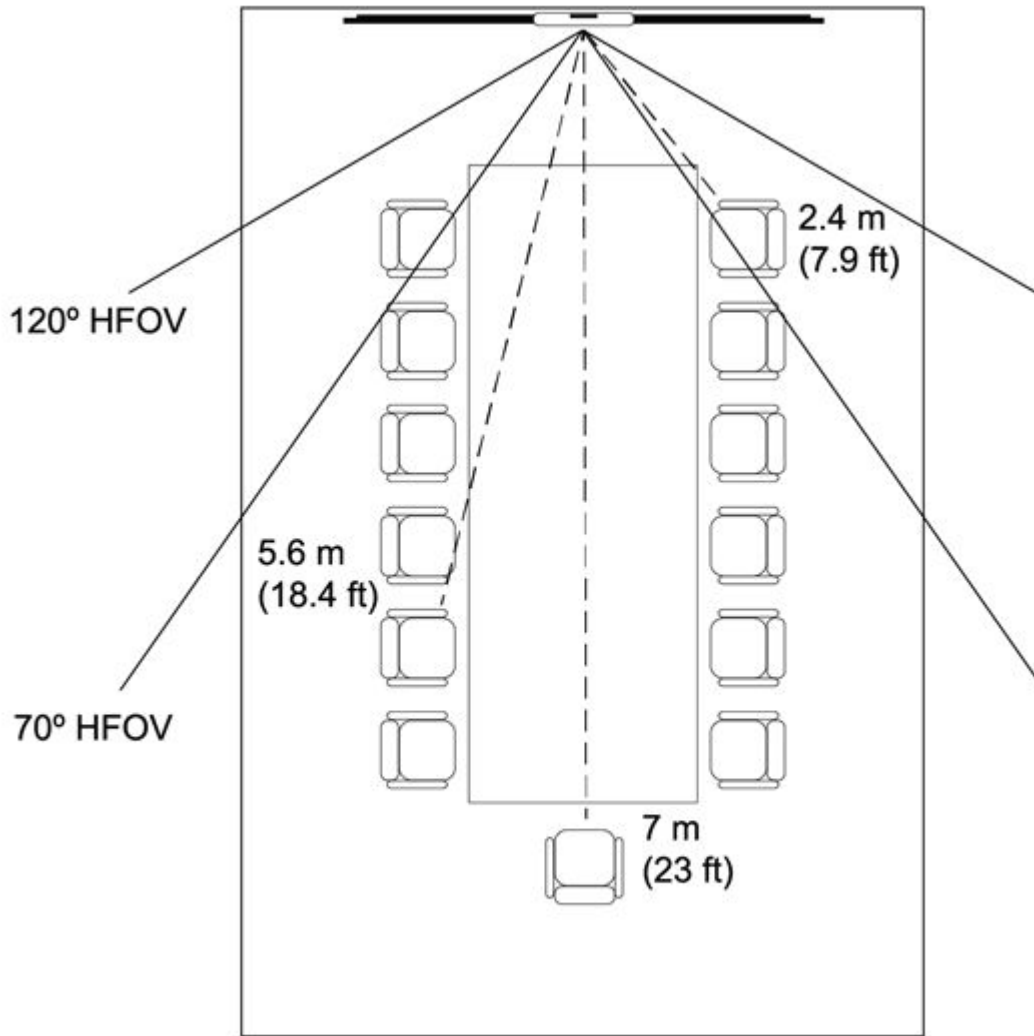

**Studio X70**

Studio X70 systems are suitable for large and medium-sized conference rooms.

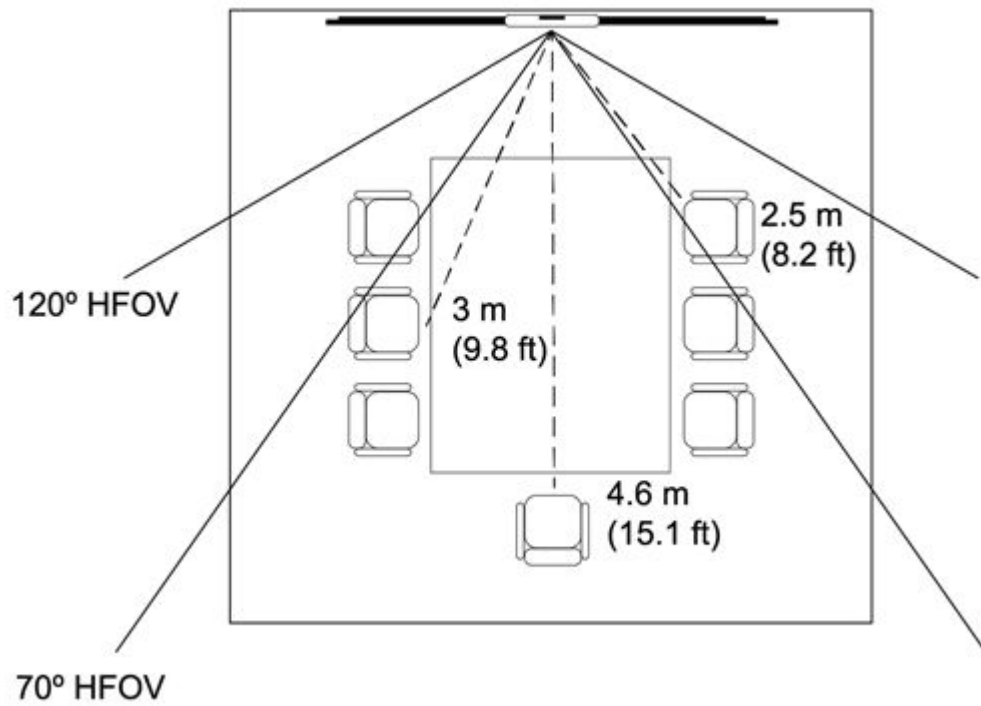

**Studio X50**

Studio X50 systems are suitable for small and medium-sized conference rooms.

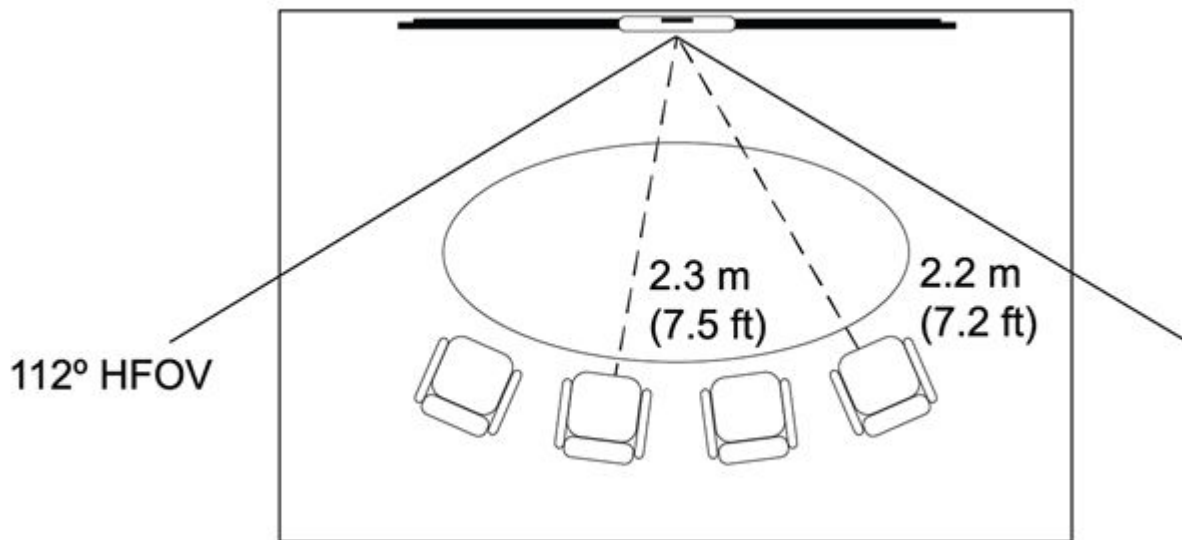

**Studio X30**

Studio X30 systems work best for huddle conference rooms.

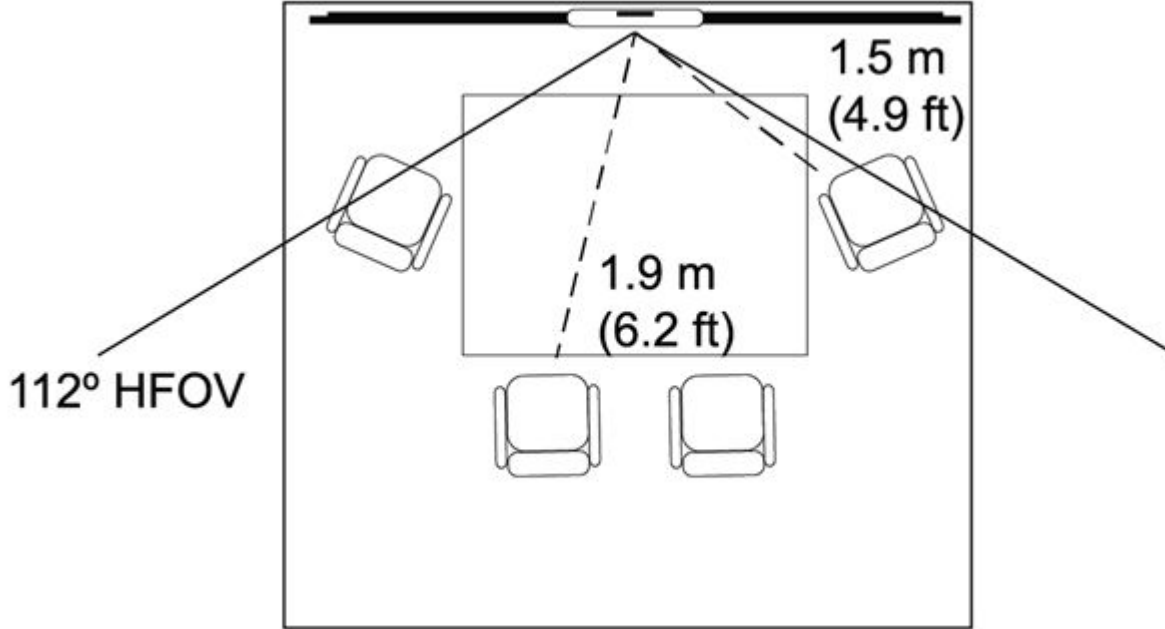

## Codec Placement

The location of your codec depends on several factors, and correct placement ensures a great conferencing experience.

Measure your space before installation and plan the codec placement.

### Task

- 1 Place the codec within the standard cable lengths to ensure that cables reach the required equipment. You may need additional cables or connectors if you place equipment outside of the standard cable lengths.

**Note:** If you need to extend the length of cables between your system components, Poly recommends working with your A/V integrator or partner. They can help you implement certified solutions that work with the unique requirements in your environment.

- 2 Place your codec in an area that provides ventilation around the codec. Poly recommends a minimum distance of 35 mm (1.3 inches) on each side of the codec. Covering the ventilation opening can result in overheating and system instability.

**Important:** Review the important safeguards for your system mentioned in the Safety and Regulatory Notices located at the Poly Online Support Center.

## System Characteristics and Cable Lengths

The following tables provide the characteristics and cable lengths for the G7500, Studio X Family systems, and Studio E70 camera.

### G7500

G7500 systems are suitable for large-sized conference rooms.

## G7500 Characteristics and Cable Lengths

Characteristic	Description
Physical	34.92 cm W × 3.81 cm H × 13.87 cm D (13.75 in. × 1.5 in × 5.5 in.) 0.95 kg (2.1 lbs)
Screen	Supplied HDMI cable (2) length: 1.83 m (6 ft)
Camera cable	Supplied HDCI cable length: 3 m (9.8 ft)
Poly IP Table Microphone	Supplied shielded LAN cable length: 7.6 m (25 ft)
LAN connection	Supplied codec network cable length: 3.6 m (12 ft)
Power supply cable	Approximately 3 m (9.8 ft) supplied for the codec  <b>Note:</b> The display and other devices associated with the system may require additional outlets.
Power consumption	Typical operating voltage/power 100 to 240 VAC, 50/60 Hz 54V DC input, 3.34A, 180W Typical BTU/h: 65

## Studio E70

Studio E70 cameras (connected with G7500 systems) are suitable for large-sized conference rooms.

### Studio E70 Characteristics and Cable Lengths

Characteristic	Description
Physical	321 mm W x 102 mm H x 89.1 mm D (12.63 in x 4.02 in x 3.51 in) 907 g (2 lbs)
Cameras	120° HFOV, 70° HFOV
Power over Ethernet (PoE) connection	Supplied network cable length: 4.57 m (15 ft)
Power consumption	12VDC at 1.2A External power supply input spec: 100-240V 50/60Hz, 1.5A External power supply output spec: 12.0V DC, 5.0A, 60.0W, L.P.S

## Studio X70

Enter a short description of your reference here (optional).

### Studio X70 Characteristics and Cable Lengths

Characteristic	Description
Physical	40.18 mm W × 135.8 mm H × 119.33 mm D (33.1 in. × 5.3 in. × 4.6 in.); 7.05 lbs/3.2 kg
Screen	Supplied HDMI cable (2) length: 1.83 m (6 ft)

Characteristic	Description
Cameras	Supplied HDCI cable length: 3 m (9.8 ft); 120° HFOV, 70° HFOV
LAN connection	Supplied codec network cable length: 3.6 m (12 ft)
Power supply cable	Approximately 3 m (9.8 ft) supplied for the codec <b>Note:</b> The display and other devices associated with the system may require additional outlets.
Power consumption	Typical operating voltage/power 37 VA @ 120 V @ 60 Hz; 37 VA @ 230 V @ 50/60 Hz Typical BTU/h 65

## Studio X50

Studio X50 systems are suitable for small-sized conference rooms.

### Studio X50 Characteristics and Cable Lengths

Characteristic	Description
Physical	762 mm W × 102 mm H × 102 mm D (30 in × 4 in × 4 in); 5.6 lbs/ 2.54 kg
Screen	Supplied HDMI cable (2) length: 1.83 m (6 ft)
Camera	112° HFOV
LAN connection	Supplied codec network cable length: 4.57 m (15 ft)
Power consumption	Typical operating voltage/power: 37 VA @ 120 V @ 60 Hz; 37 VA @ 230 V @ 50/60 Hz Typical BTU/h: 65

## Studio X30

Studio X30 systems are suitable for huddle conference rooms.

### Studio X30 Characteristics and Cable Lengths

Characteristic	Description
Physical	441.8 mm W x 62.5 mm H x 61.6 mm D (17.38 in. x 2.46 in. x 2.42 in.); 1.6 lbs/.73 kg
Screen	Supplied HDMI cable (2) length: 1.83 m (6 ft)
Camera	112° HFOV
LAN connection	Supplied codec network cable length: 4.57 m (15 ft)

Characteristic	Description
Power consumption	Typical operating voltage/power: 37 VA @ 120 V @ 60 Hz; 37 VA @ 230 V @ 50/60 Hz Typical BTU/h: 65

## LAN Ports and Power Outlet Placement

Planning cable layouts and confirming the number of power outlets you need are important considerations before installing a Poly system.

Consider the following power outlet and cabling tips:

- Poly systems may need access to multiple Ethernet ports on the same subnet. If possible, place the teleconferencing system near LAN ports in the wall. Make sure there are available Ethernet ports near the location of a paired Touch Controller device or Trio phone for the best installation experience.
- Poly recommends running all cables underneath the floor to avoid accidentally tripping or falling. If you can't run cables under the floor, consider using an in-carpet solution or an over-the-floor cable cover.
- Verify that the room includes enough power outlets located near your system and controller if the controller isn't using PoE.

## Camera Placement

When planning the placement of your cameras, think about room size, monitor location, camera type, and other options to ensure you provide the optimum viewing experience for the far-side.

### Camera types

Use the camera that is best suited to your conference room size. Choose from the following options:

- Use the built-in camera with your Studio X70, Studio X50, or Studio X30 system.
- Connect a Studio E70 camera with a G7500 system or as an external secondary camera with a Studio X70 or Studio X50 system.
- Connect other supported cameras with your G7500, Studio X70, or Studio X50 system.

### Monitor and Camera Position

Consider the following monitor placement and camera mounting tips:

- Mount the monitor so that the center of the display is at eye level with seated participants, approximately 1.07 m (42 in.) from the finished floor. Then position the camera as close to that level as possible.
- When placing your camera on the monitor, choose locations that are near to the center lines (vertical and horizontal) of the display showing the far-side speakers. This location lends itself to a natural sense of eye contact.
- Don't point your camera at a busy background. This includes busy patterns or interior and exterior windows that have a lot of traffic.
- Centering a camera between multiple displays may be aesthetically pleasing, but it can compromise eye contact.
- The parallax error appears less pronounced as the distance between the camera and the subject increases. Participants in a large conference room with offset cameras may be able to view eye contact as normal, but huddle or focus rooms may be too small for the camera distance to compensate for the perceived error.
- Don't mount cameras at extreme heights and then point them down like surveillance cameras. Mounting cameras at extreme heights may cause eye contact issues and skew the images of people. Detections may also become a problem.
- A practical maximum height is 1.8 m to 2.1 m (6 ft to 7 ft) from the floor to the center line of the camera housing (the lower camera lens).

See [Recommended Room Dimensions](#) for recommended maximum camera distances when setting up G7500 and Studio X Family systems.

## Camera Placement on Monitors

The position and elevation of the monitor in a meeting room often determines whether you mount the camera above or below the display.

Ideally, position the monitor so that the center of the display is at eye level of seated participants, approximately 1.07 m (42 in.) from the finished floor. Then mount the camera as close to that level as possible—this is usually on top of the monitor.

In some circumstances however, the monitor may have to be at an elevated position relative to the audience, meaning you must mount the camera in an inverted setup below the monitor to meet the recommended participant eyeline positioning.

The following diagram shows a participant sitting in a room with the camera mounted below the monitor, instead of the recommended position of near the center lines of the display. Since the participant must look up at the display to see the relevant conference information, the far side receives a view of the participant looking away from and much higher than the camera view.

**Note:** The camera placement guidance presented in this guide may not apply to special applications and environments.

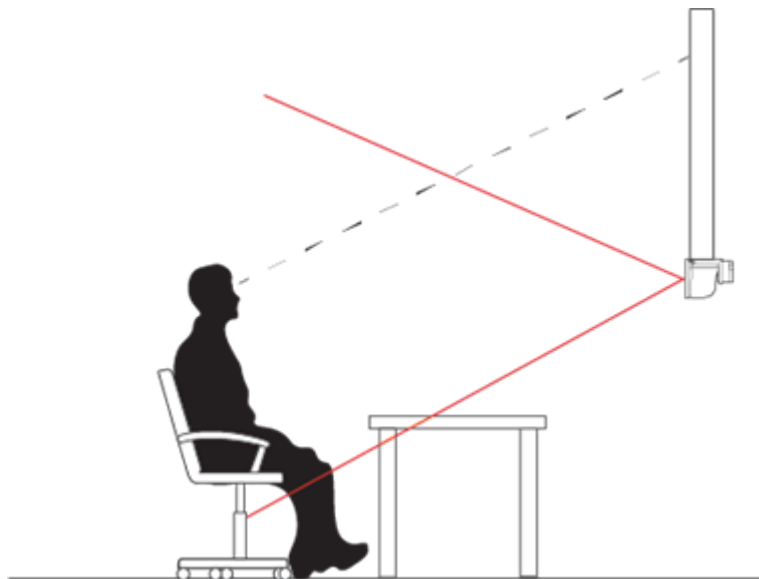

**Figure 1: Camera mounted below monitor**

Note the following:

- Placing cameras outside an ideal location can have negative results. For example, positioning a camera below a monitor can render an unintentional and possibly unflattering perspective to the far-side viewers if a meeting attendee walks in front of the camera.
- Positioning cameras too far outside the center lines of the display can also create a parallax error, which is when the eyes of the person on camera look askance at the remote speaker. A significant loss of eye contact can cause a sense of inattention or mistrust, so avoiding those appearances is important.

### Field of View

Make sure your camera uses a wide enough field of view (FOV) that covers the participants located furthest from the camera. For example, a G7500 system with a Studio E70 camera is ideal for a large room configuration because the camera specifications offer both a wide field of view: 120-degree horizontal field of view (HFOV) and a narrower 70-degree HFOV, with 7.62 m (25 ft) maximum user distance.

#### Studio E70 Field of View

The Studio E70 camera has an articulating hinge located at the bottom of its base. You can manipulate this hinge to rotate the camera from side to side or to tilt it up and down to an angle that provides a wide enough field of view for your conference. For best results, Poly recommends that you position the camera so that its centerline points to the person seated furthest from the camera.



The following diagrams show the range of the Studio E70 camera's narrow vertical field of view (VFOV) (11 degrees) and wide VFOV (49 degrees) when you position the camera at level and forward tilt positions, and the room participant furthest from the camera is at various distances.

**Note:** The Studio E70 electronics don't allow pan or tilt when the camera is at full-wide angle. You must zoom in to allow pan or tilt.

The following diagram shows the perspective of the Studio E70 camera when the room participant at the furthest distance from the camera is 1.83 m (6 ft) away. At this distance, moderately tilting the camera forward captures the room participant in the camera's narrow and wide VFOV.

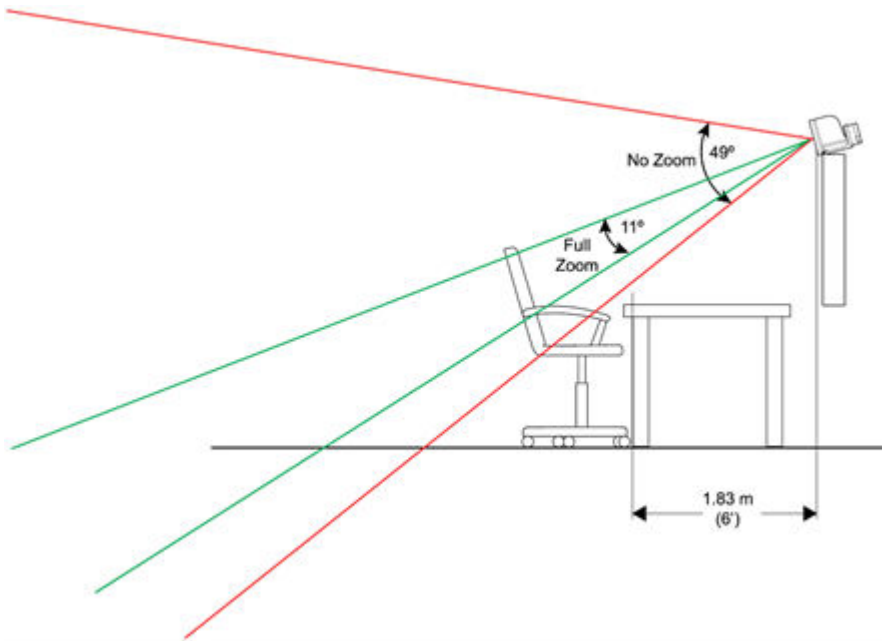

**Figure 2: Studio E70 in a moderate tilt position**

The following diagram shows the perspective of the Studio E70 camera when the room participant at the furthest distance from the camera is 3.66 m (12 ft) away. At this distance, slightly tilting the camera forward captures the room participant in the camera's narrow and wide VFOV.

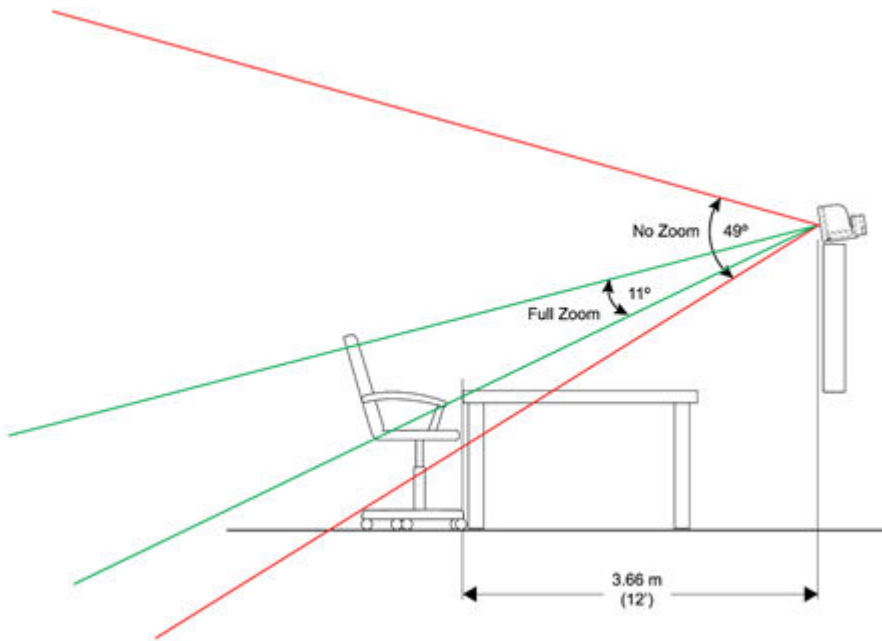

**Figure 3: Studio E70 in a modest tilt position**

The following diagram shows the perspective of the Studio E70 camera when the room participant at the furthest distance from the camera is 7.62 m (25 ft) away. At this distance, placing the camera at a level position captures the room participant in the camera's narrow and wide VFOV.

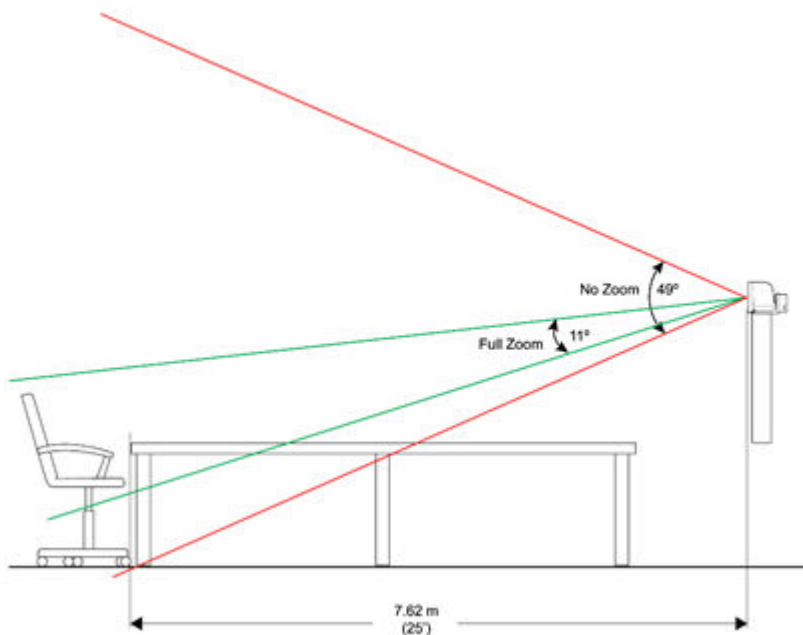

**Figure 4: Studio E70 in a level position**

### Camera Auto-Framing

Poly camera framing technology can automatically frame groups of people and follow conversations in meeting rooms.

Position the cameras in the room to provide optimal framing performance. Framing options and behavior depend on your connected camera.

Consider the following tips for obtaining optimal camera framing performance:

- Keep the camera FOV free of distractions. Avoid having an open doorway, glass wall to a corridor, or a window in the background of the meeting participants.
- Maintain a consistent color temperature of room lighting including any contribution by outside windows.
- Don't place items in the camera's FOV that can distract the camera's system performance. Examples are human-like figures or statues on the meeting table or human facial images on the wall. The camera may detect these and decide to focus on them.
- Refer to a camera's distance specifications to avoid detection failures.

See your conferencing application's support documentation for details on supported cameras, multicamera support, certification, and camera switching support.

### Camera Framing Examples

The following diagrams show camera framing for the Studio E70 camera and Studio X Family systems at various zoom settings when room participants are specific distances from the camera.

#### Camera Framing Examples

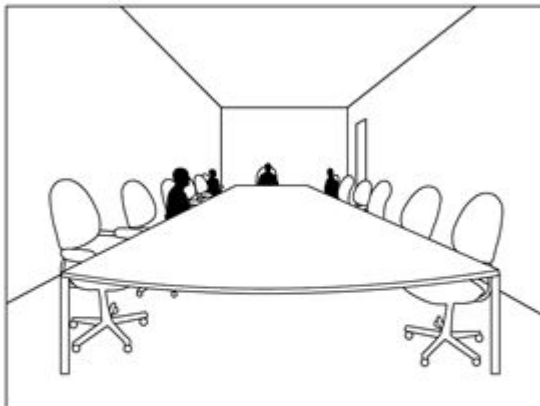

Studio E70 camera speaker framing view  
7.62 m (25 ft) distance  
No Zoom

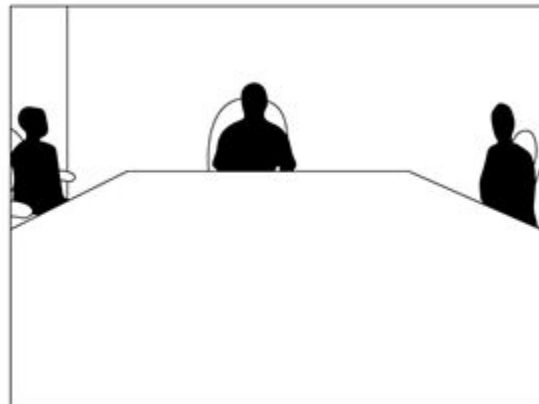

Studio E70 camera speaker framing view  
7.62 m (25 ft) distance  
Full HD Zoom

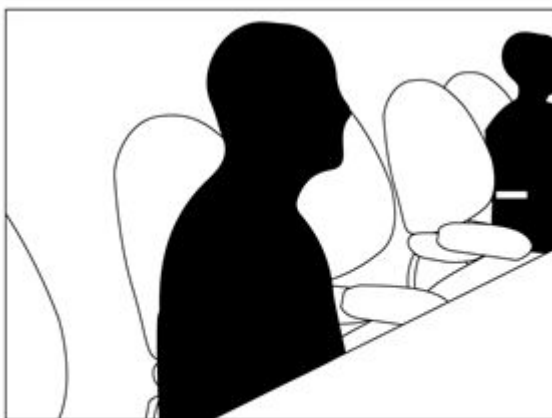

Studio E70 camera speaker framing view  
3.66 m (12 ft) distance  
Full HD Zoom

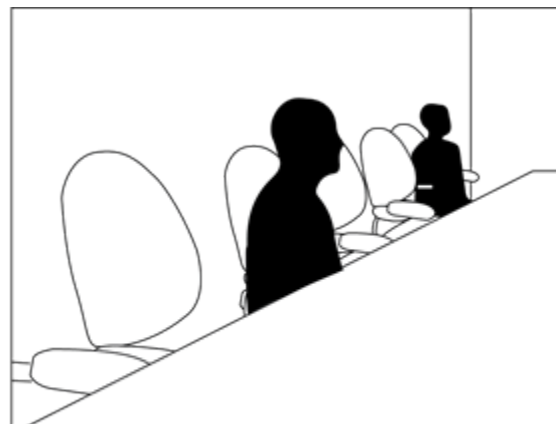

Studio X30/Studio X50 speaker framing view  
3.66 m (12 ft) distance  
Full HD Zoom

## Microphone Placement

The ideal location for microphones in a conference environment is near the speaker. When speakers see the microphone while in a seated position relative to the video screen and within the distance guidelines presented in this document, the room microphone detects their voices more clearly.

Consider the following tips for optimal microphone placement:

**Note:** Sound levels decrease by one-fourth at the microphone as the distance from the speaker doubles, which can quickly cause an unfavorable audio experience.

- Placing microphones with a similar distance between speakers helps the far end hear conversations more smoothly and even sounding.
- Direct sound is preferable to reflected sound. Avoid positioning speakers with their back to a microphone, which can cause their voices to sound dull and contain significant amounts of room reverberance.
- Position a table microphone closer to the display to enable the microphone to hear meeting participants directly, which improves the fidelity of the audio sent to the far end.
- Multiple microphones are ideal for meetings with rectangular conference tables where people sit along a long edge. Using multiple microphones ensures there's even coverage of each speaker.
- Avoid placing any microphones where direct airflow from fans or HVAC might touch the microphone.
- The minimum distance to place a microphone in relation to a room loudspeaker is 1 m (3 ft).

### Table Microphones

The optimal placement for table microphones is about an arm's length away from the speaker and centered between the speaker and the video screen showing the far end image. For small groups, positioning the microphone in the middle of the table and between the speakers and the video screen is best.

### Ceiling Microphones

Poly recommends placing ceiling microphones above the conference room table and shifted toward the video screen away from a group of people seated at a table.

## Audio Pickup Ranges

Understanding the audio pickup range for a microphone can also help you determine the most suitable locations for your microphones. Microphone pickup range refers to the distance at which a microphone is sensitive to sound.

The following tables list the typical and maximum audio pickup ranges for the Studio X Family built-in microphones and common microphone solutions. Typical audio pickup ranges refer to acceptable audio quality under most room conditions without causing the far end difficulty in understanding the speech.

Distances that are further than the typical range might be acceptable under conditions with good room acoustics (low reverberance and noise). The maximum audio pickup range value refers to the recommended furthest distance under any room conditions.

**Note:** All distances are subject to the ambient noise and reverberant characteristics of the room in use.

### Audio Pickup Ranges for Studio X Family Built-in Microphones

System	Typical Distance	Maximum Distance
Studio X70 and Studio X50	3.5 m (11.5 ft)	7.6 m (25 ft)
Studio X30	2.5 m (8.2 ft)	4.6 m (15 ft)

## Audio Pickup Ranges for Common Microphone Solutions

Microphone Solution	Typical Distance	Maximum Distance
Poly IP table microphone	Circle with a radius of 1 m (3.3 ft) away from the microphone	Circle with a radius of 2.5 m (8.2 ft) away from the microphone
Poly IP ceiling microphone	Circle with a radius of 1.5 m (4.9 ft) directly below the microphone	Circle with a radius of 3.5 m (11.5 ft) directly below the microphone

### Example Microphone Placement Layouts

This section includes diagrams of example layouts of Poly IP table microphones and ceiling microphones. The circles in the diagrams represent the audio pickup range for typical (small circle) and maximum (large circle) distances from the system.

#### 1 Table Microphone

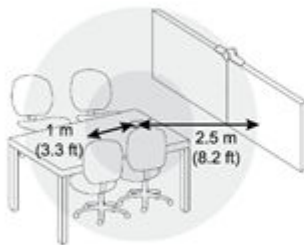

1 m (3.3 ft) = works under all room conditions  
 2.5 m (8.2 ft) = maximum distance under typical room conditions

#### 1 Ceiling Microphone

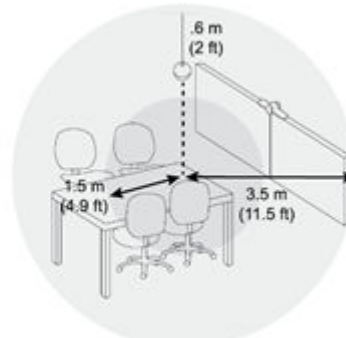

1.5 m (4.9 ft) = works under all room conditions  
 3.5 m (11.5 ft) = maximum distance under typical room conditions

#### 2 Table Microphones



#### 2 Ceiling Microphones

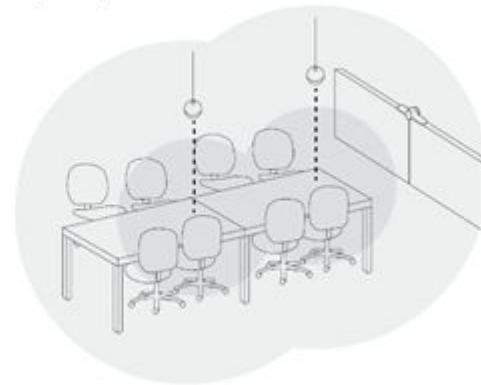

### 3 Table Microphones

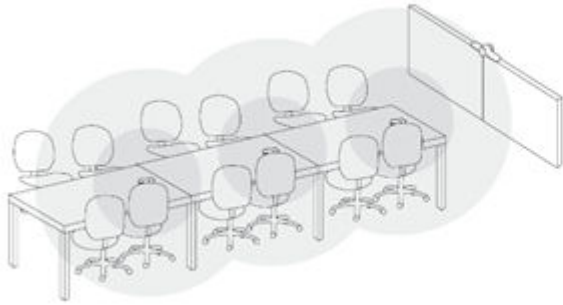

### 3 Ceiling Microphones

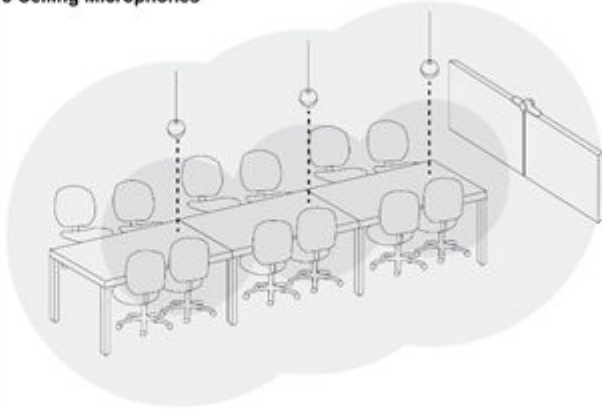

## Maximum Volume and Full Duplex

A room's audio level can affect the audio quality during a meeting. Using excessively loud room audio can alter the behavior of acoustic echo cancellation (AEC), the technology that provides full-duplex (interactive or two-way) communication in a conference environment.

When AEC detects excessive room gain, it switches to half-duplex (one-way) communication in which room participants must take turns speaking or shout to be heard above another person who is speaking.

Studio X Family systems have integrated speaker and microphone components within their structure. These systems are more susceptible to the consequences of excessive room gain than G7500 systems that have mechanically separated microphone and speaker components.

Poly recommends the following to minimize room gain:

- Use an expansion microphone to eliminate the proximity of the microphone to the loudspeaker.
- Reduce the remote speaker volume in the room. In most conference spaces, remote video participants are in the same room and use a conversational loudness level of approximately 72 dBA SPL at the listener.

## Display Options

G7500, Studio X70, and Studio X50 systems are available in single- or dual-monitor configurations. Poly recommends setting up these systems in the dual-monitor configuration.

Studio X30 systems are available only in single-monitor configuration. You can use touch-enabled monitors with G7500 and Studio X Family systems for an enhanced experience.

# Poly Acoustic Fence and Poly Acoustic Fence with Beam Shaping Technology

Poly Acoustic Fence and Poly Acoustic Fence with Beam Shaping are different technologies that reduce unwanted sounds in a conference setting. G7500 systems support Poly Acoustic Fence, while Studio X Family systems support Poly Acoustic Fence with Beam Shaping.

## Poly Acoustic Fence with G7500 Systems

Poly Acoustic Fence limits the pickup of microphone audio to designated areas in open office environments. This feature only affects the audio transmitted from the room to the far end, not the audio output from the far end.

Poly Acoustic Fence consists of primary microphones and fence microphones that determine the area where audio is picked up and sent to the far end. The primary microphones pick up the audio within the fence boundaries. The fence microphones define the boundary of audio that is picked up and sent to the far end. Any audio outside of the fence isn't picked up.

Poly Acoustic Fence technology provides the following features:

- Mutes sounds outside the fence when no one is speaking inside it.
- Lowers sounds outside the fence by 12 dB when someone is speaking inside it.
- Mutes the people speaking in the room when someone leaves the fenced area.
- Enables you to adjust the width of the audio fence beam to define the area where sounds are picked up.

## Poly Acoustic Fence Ceiling Microphone Array

The fence ceiling microphone array is specially processed to develop a null of approximately +/- 45 degrees, centered at the location of the dot on the ceiling microphone array. This null helps substantially in discriminating between sounds originating inside versus outside the fence region.

When hanging the fence ceiling microphone array, it's very important to rotate the ceiling microphone arrays so that the dot points to the middle of the fence region. Roughly, sounds outside the +/- 45-degree beam width are outside the fence region, and sounds inside the +/- 45-degree beam width are inside the fence region.



Figure 5: Ceiling microphone array dot location

## Supported Poly Acoustic Fence Configurations

The following table lists the possible configurations supported for Poly Acoustic Fence with Poly G7500 systems.

**Note:** If you mix table and ceiling microphones, the primary microphone must be a table microphone. The primary microphone can be a ceiling microphone if you use only that type of microphone.

## Supported Poly Acoustic Fence Configurations for G7500

Primary Microphone	Fence Microphone	Configuration
One ceiling microphone array	One or two ceiling microphone arrays	Rotate fence ceiling microphone arrays so that the dot points to the primary microphone area. The region opposite the dot is the area where unwanted sounds occur. The first ceiling microphone array you pair with the system is the primary microphone.
One table microphone array	One ceiling microphone array directly above table microphone array	The primary pick-up area is a ~ +/- 45-degree area beneath the ceiling microphone array. Rotation isn't necessary for this configuration.
One table microphone array	Two ceiling microphone arrays	Rotate the fence ceiling microphone arrays so that the dot points to the primary microphone area. The region opposite the dot is the area where unwanted sounds occur.

### Example Layouts for Poly Acoustic Fence

This section includes diagrams of example Poly Acoustic Fence configuration layouts.

The following example shows the table microphone as the primary microphone, and the two ceiling microphones create the fence.



**1 Table Microphone &  
2 Ceiling Microphones**

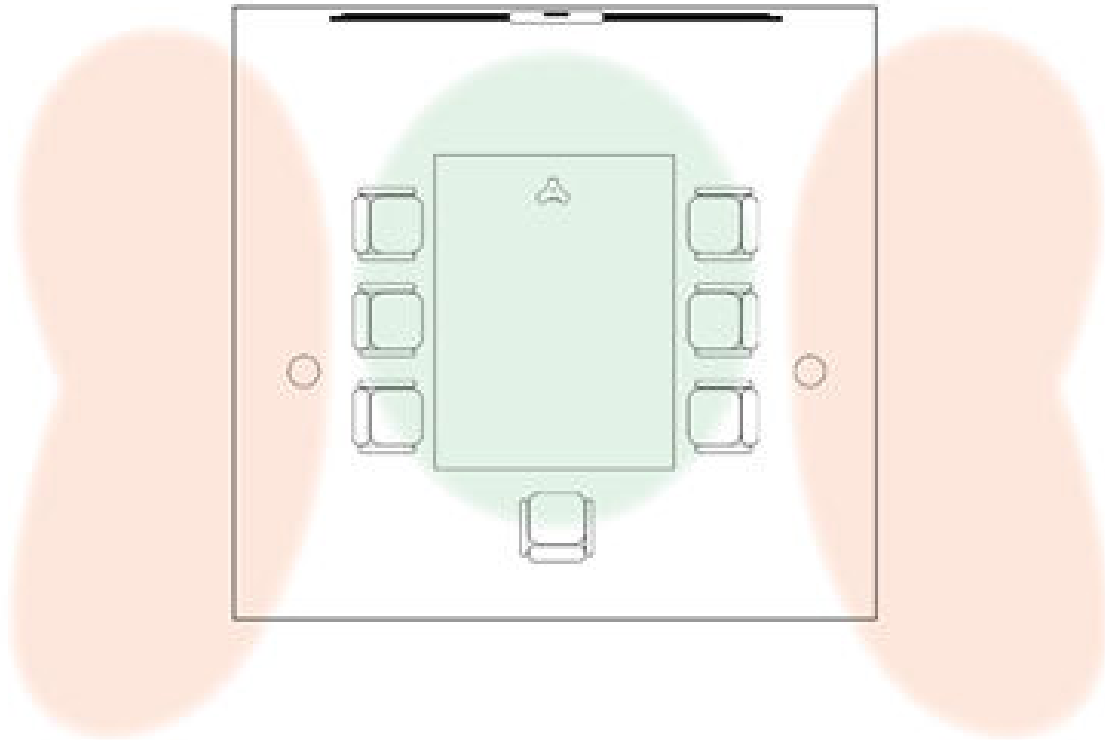
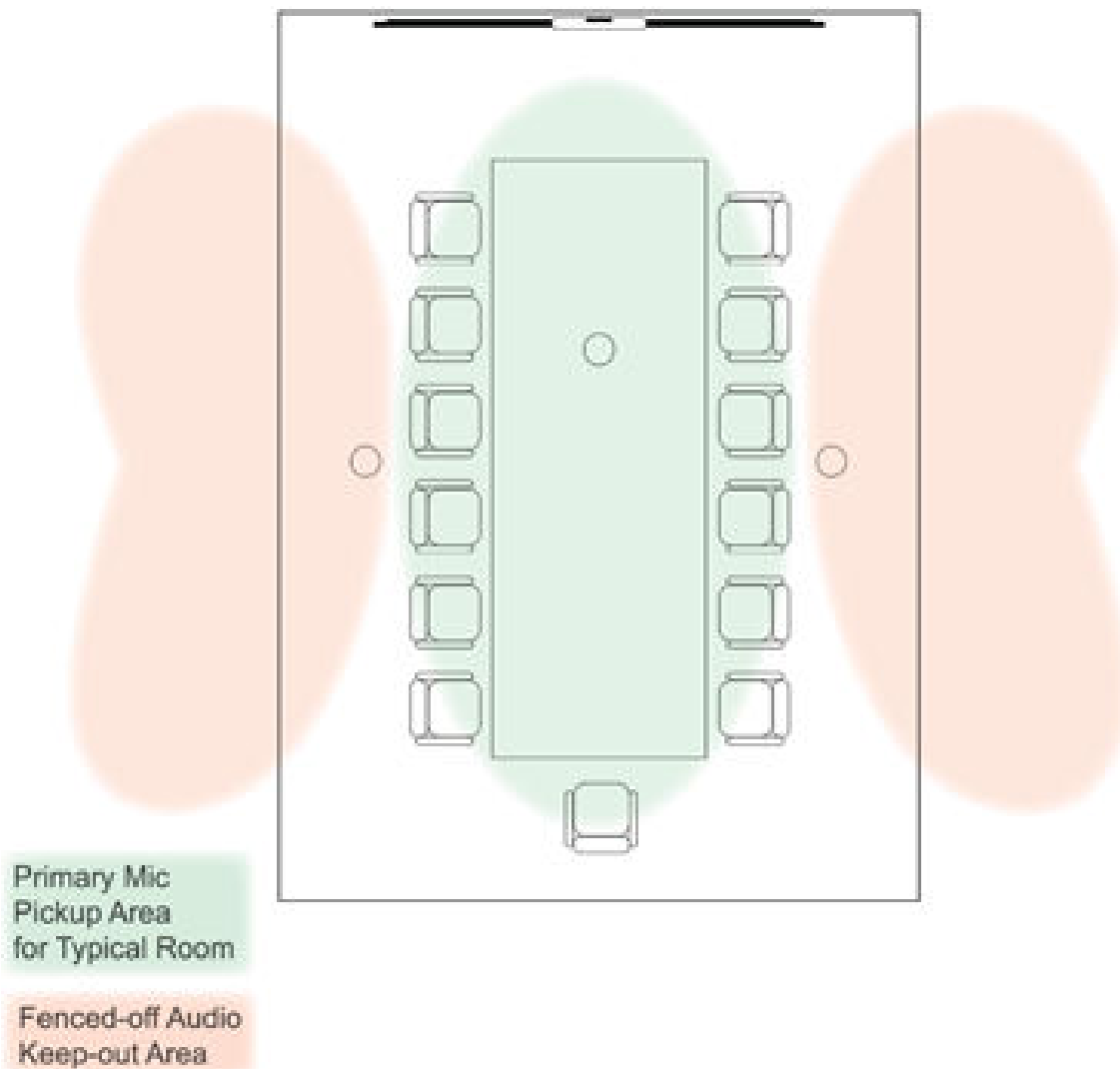

Table Mic  
Pickup Area  
for Typical Room

Fenced-off Audio  
Keep-out Area

The following example shows one ceiling microphone array as the primary microphone, and two additional ceiling microphone arrays create the fence.

### 3 Ceiling Microphones



#### Configure Poly Acoustic Fence

There are three steps for setting up Poly Acoustic Fence with G7500 systems.

Steps to configure Poly Acoustic Fence:

- 1 Enable the Poly Acoustic Fence feature.
- 2 Specify the primary IP-based microphone and then up to two secondary IP-based microphones to create the fence. The boundary radius can be 0.61 m (2 ft) or more around the microphones.
- 3 Adjust the Poly Acoustic Fence Sensitivity to the appropriate radius.

**Note:** Microphones connected to a Poly Microphone IP Adapter currently don't support Poly Acoustic Fence.

#### Enable Poly Acoustic Fence

Enable the Poly Acoustic Fence feature for G7500 systems.

**Note:** This option isn't available if you enable Polycom StereoSurround.

#### Task

- 1 In the system web interface, go to **Audio/Video > Audio > General Audio Settings**.
- 2 Select the **Enable Acoustic Fence** check box.

### Specify the Primary and Fence Microphones

Use only ceiling microphones or a mix of ceiling and table microphones to use Poly Acoustic Fence with your G7500 system. You can connect up to three microphones directly to your system.

**Note:** If you use a mix of table and ceiling microphones, the primary microphone must be a table microphone. The primary microphone can be a ceiling microphone if you use only that type of microphone.

The order you pair your microphones is important if all microphones are ceiling microphones. The first IP microphone that pairs with the system is designated the primary microphone, and the remaining microphones are the fence microphones. If you connect a table microphone, it becomes the primary microphone.

By default, a microphone pairs to the system when you connect it (unless you've disabled automatic pairing).

**Important:** When using Poly Acoustic Fence technology, remember which microphone is the primary one. If you disconnect this microphone, Poly Acoustic Fence no longer works, and you must reconnect all microphones (starting with the primary microphone) for it to work again.

To specify the primary and fence microphones:

#### Task

- 1 Connect the primary microphone to an LLN port on the back of your system.
- 2 Connect one or more other microphones.

### Adjust the Poly Acoustic Fence Sensitivity

Adjust the Poly Acoustic Fence sensitivity to define the audio fence radius around the G7500 system.

**Note:** This option isn't available if you enable Polycom StereoSurround.

To enable and configure Poly Acoustic Fence:

#### Task

- 1 In the system web interface, go to **Audio/Video > Audio > General Audio Settings**.
- 2 Set the Acoustic Fence Sensitivity to adjust the radius of the fence area about the primary microphone.

**Note:** Larger values provide a larger radius.

### Specify a Different Primary Microphone

You can change the primary microphone that you're using for Poly Acoustic Fence.

#### Task

Specify a different primary microphone:

- 1 Disconnect all microphones from the LLN ports on the back of your system.
- 2 Reconnect the microphone that you want to be the primary.  
Your primary microphone is set up.
- 3 Connect one or more other microphones.

## Poly Acoustic Fence with Beam Shaping with Studio X Family Systems

Poly Acoustic Fence with Beam Shaping greatly reduces sounds outside a well-defined beam determined by a built-in microphone array.

- The beam is centered on a perpendicular line to the center of the Studio X Family system.
- The beam width can vary from a width of 12 degrees to 120 degrees via menu controls.
- There's no discrimination of sounds based on the tilt angle of the sound source (only the pan angle).

## Configure Poly Acoustic Fence with Beam Shaping

There are two steps for setting up Poly Acoustic Fence with Beam Shaping with Studio X Family systems.

### Steps to configure Poly Acoustic Fence with Beam Shaping:

- 1 Enable the Poly Acoustic Fence with Beam Shaping feature.
- 2 Adjust the width of the audio fence beam so that the built-in microphone picks up sound in the area you want.

### Enable Poly Acoustic Fence with Beam Shaping

Enable the Poly Acoustic Fence with Beam Shaping feature for Studio X Family systems.

**Note:** This option isn't available if you enable Polycom StereoSurround.

### Task

#### To enable Poly Acoustic Fence with Beam Shaping:

- 1 In the system web interface, go to **Audio/Video > Audio > General Audio Settings**.
- 2 Select the **Enable Acoustic Fence** check box.

### Adjust Poly Acoustic Fence with Beam Shaping Sensitivity

Adjust the Poly Acoustic Fence feature to define the audio fence around the Studio X Family system.

### Task

#### To enable Poly Acoustic Fence with Beam Shaping:

- 1 In the system web interface, go to **Audio/Video > Audio > General Audio Settings**.
- 2 Set the **Acoustic Fence Sensitivity** to adjust the width of the audio fence beam. Higher values increase the width of the audio fence beam.

Use 1 for the narrowest beam (12 degrees) or 10 for the widest beam (120 degrees). If you set Acoustic Fence Sensitivity to 0, the system mutes the microphone(s). The total angles are the setting number multiplied by 12.

### Example Layouts for Poly Acoustic Fence with Beam Shaping

The following example layouts show the audio fence beam and noise keep out areas when the beam width for a Studio X Family system built-in microphone is set to a narrow, medium, or wide value.

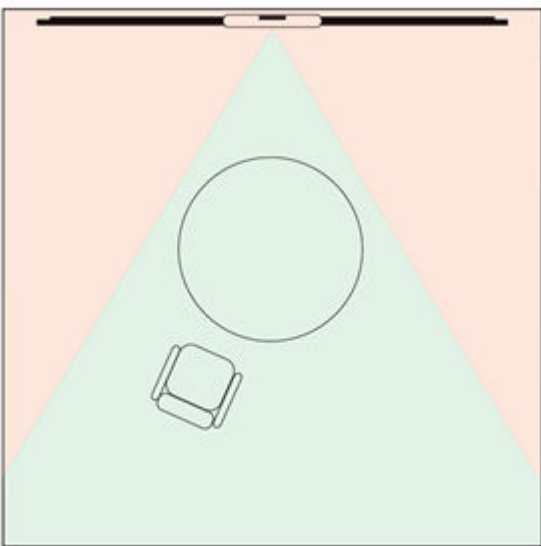

Figure 6: Example layout for a narrow beam width configuration

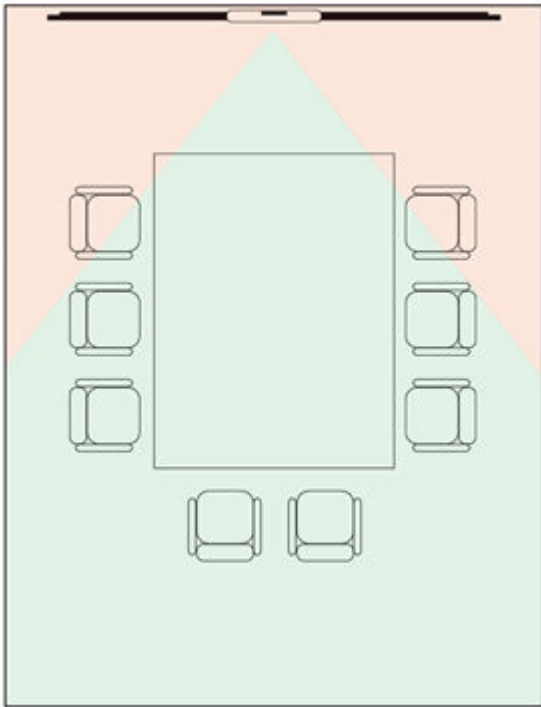

Figure 7: Example layout for a medium beam width configuration

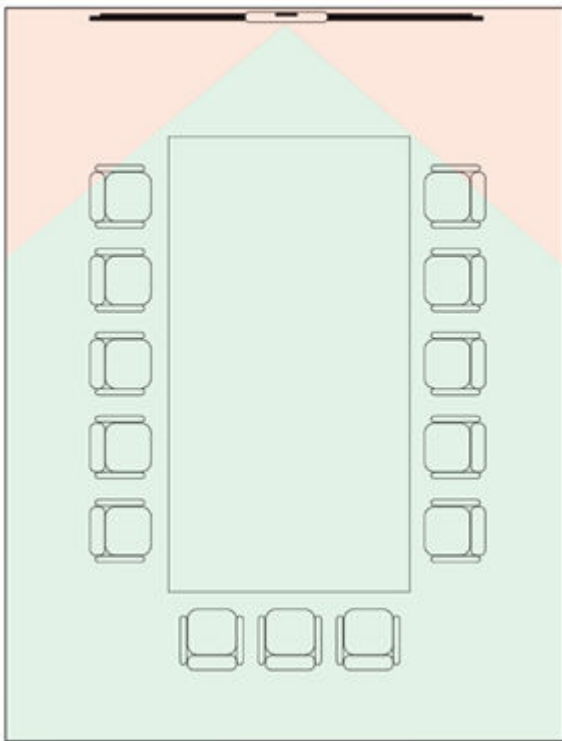

Figure 8: Example layout for a wide beam width configuration